

Terms & Conditions

ORDERING INFORMATION:

To order any item please refer to the proper catalog section and list quantity, catalog number and description. Should you have any questions regarding items shown, or special requirements that are not shown, please contact your nearest Field Representative or GIC Thermodynamics, Inc. 4949 Delemere Ave., Royal Oak, Michigan 48073. Phone: 248-280-1648, Fax: 248-280-0998, E-mail: sales@gicsensors.com.

ENGINEERING:

If the unit you require is not shown in this catalog contact the factory or field representative. Our engineers will assist you in providing the right sensor for your application.

QUANTITY (VIQ)

For all items carried in stock (including customer proprietary stock) GIC will ship the exact quantity requested on an order. In the manufacture of non-stock or made-to-order products however, it is necessary to allow for losses in production. We therefore reserve the right to ship and invoice the following variation in quantities (VIQ) of units unless a specific in-writing agreement to the contrary is made prior to the acceptance of the order. With the exception of pre-spooled lengths of Thermocouple and Extension Wire carried in stock a +/- 5% variation in quantity applies to any purchase. **No VIQ = add 5% to order value.**

MINIMUM PURCHASE REQUIREMENTS

Stock Inventory (only): \$50.00
Made To Order (Per Item): \$100.00
Product Mix (Stock & Made to Order): \$100.00

VARIATION IN QTY. (VIQ)

QTY ORDERED	VARIATION
1 to 9	No Variation
10 to 24	+/- 1 unit
25 to 49	+/- 2 units
50 to 99	+/- 3 units
100+	+/- 4%

DELIVERY

Stock Sensors: Ship same day if order is received by 2pm eastern time.

Standard Production Time: 3 weeks ARO.

Accelerated Delivery: 1 day to 2 weeks depending on availability of parts and labor - for a nominal charge we can take care of your emergency situations. Standard delivery terms: are F.O.B. GIC Plant. Unless otherwise specified in the order GIC will select the carrier, prepay the freight and include charges on the invoice. Responsibility for the shipment will pass to the buyer at the F.O.B. point.

PAYMENT TERMS

Standard payment terms are Net 30 days with approved credit. All major credit cards and approved C.O.D. shipments.

CANCELLATION CHARGES

Orders are subject to a cancellation charge of which the amount will be determined by GIC, at the time of cancellation, based on the total of production completed. There is no charge for the cancellation of stock sensors.

PROPRIETARY STOCK

Let GIC carry your finished sensor inventory. Get off the shelf delivery of custom sensors made to your exact specifications.

BLANKET ORDERS

Advise us of your monthly or annual requirements for guaranteed scheduled deliveries at the best possible price.

WARRANTY

GIC products are warranted against defects in workmanship and materials. No other express warranty, written or oral applies. No person is authorized to give any other warranty or assume any liability except by written statement from an officer of GIC Thermodynamics, Inc.

WARRANTY PERIOD

Product warranty extends for 12 months from date of shipment from the factory or authorized distributor. Products must be installed and maintained in accordance with GIC instructions. Users are responsible for the suitability of the products to their application. There is no warranty against damage resulting from corrosion, misapplication, improper specification or other operating conditions beyond our control. Claims against carriers for damage in transit must be filed by the buyer.

RETURN POLICY

Products returned to GIC must be accompanied by a Material Return Authorization (MRA). Contact the factory or field representative for the proper paperwork and return instructions. Upon receipt, items will be examined by GIC to confirm or determine the product defect. If the product has a manufacturing defect GIC will determine if the item will be repaired, replaced or if credit will apply.

RESTOCK CHARGES

Stock sensors and accessories, which have not been used or modified, may be returned to GIC for a 20% restocking charge. All returns must be approved (MRA) for acceptance.

When it comes to temperature sensors ... “There **IS** a Difference”!

Let us show you the difference. Give GIC a chance and you will never consider another sensor supplier. Our long-standing and loyal customers' are a testament to that.

GIC Thermodynamics is a privately owned family business who specializes in temperature sensors. Consider us your sensor experts. GIC has been making custom Industrial, OEM and Power Generation sensors for over 40 years. We work closely with our customers to ensure they are getting the longest lasting, most cost effective, sensor for their application.

Utilizing the Quality Control procedures from our Mil-Spec programs, I can assure you that we are producing the highest quality sensors available.

We offer Accelerated Delivery Service for custom assemblies in as little as 24 hours. GIC will do whatever we can to get you the sensors you need when you need them. In over 40 years, no power plant has ever been held up waiting for a GIC sensor We meet our promised delivery.

Failure analysis is our forte. GIC welcomes the opportunity to help you solve any sensor problem. Send us a sample of a failed sensor and we will work with you to develop a design that will give you the performance you desire.

When it comes to temperature sensors ...“There **IS** a Difference”- Give us a chance to prove it.



Thomas Ray
President
GIC Thermodynamics

About this Catalog

This condensed catalog covers the most common Thermocouple and RTD assemblies that GIC manufactures but is by no means a complete product offering. For a larger selection of assemblies and downloadable industry specific catalogs visit our website at www.gicsensors.com. If you can't find the sensor style or information that you are looking for just call the GIC or your local sales representative and we will be happy to get you the information.

Industries we cover include:

Aerospace
Automotive
Chemical Processing
Food Processing/Sanitary

Environmental Chambers
HVAC
Metal and Heat Treating
OEM

Packaging
Plastics
Pharmaceutical
Power Generation/Electric Utility,

INDEX

Stock Sensors4	Industrial Thermocouple Assemblies	RTD Assemblies
MgO Thermocouple Assemblies	Base Metal Assembly 16	Basic Tube Assembly..... 42
Basic Assembly..... 17	Protection Tube Assembly 38	Connection Head Assembly..... 48
Connection Head Assembly..... 22	Specialty Sensors	Quick Disconnect Assembly..... 46
Quick Disconnect Assembly..... 18	Embedment Bearing Assembly ... 28,41	Transition Assembly..... 44
Replacement Assembly 37	Insulated Wire Assembly 26	Thermowell Assembly..... 50,52
Transition Assembly 20	Extension Harness T/C..... 31	Accessories
Thermowell Assemblies..... 34,36	Washer Assembly 27	Protection Tubes 55
Tube and Wire Assemblies	Melt Bolt Assembly..... 32	Thermowells 53
Rigid Tube Assembly..... 24	Nozzle Assembly 33	Thermocouple Wire..... 56
Armor Lockcap Assembly 29	Technical Data 12	Transmitters 57
Spring Lockcap Assembly..... 30		Installation & Maintenance... Back Cover

GIC Stock Sensors

METAL TRANSITION STYLE THERMOCOUPLES

Leadwire Thermocouple (900°F)

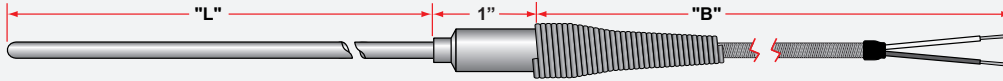

- Fiberglass Leadwire
- 316SS Sheath
- Ungrounded Junction
- MgO Filled
- Field Bendable
- Sealed Transition (600°F)
- Special Limits of Error

How to Order

Select Series Number and designated letter for the appropriate sheath diameter. Example: Type J thermocouple with a 6" x 3/16" diameter probe with 10 feet of fiberglass leads is Part Number: G706J-10GG-B.

Fiberglass Leadwire Thermocouples (900°F)

SERIES NUMBER	PROBE DIAMETER			CALIB.	LEADWIRE INSULATION	PROBE LENGTH "L"	GAUGE SIZE	SHEATH TEMP.	LEADWIRE LENGTH (B)
	1/8	3/16	1/4						
G703J-10GG	A	B	C	J	Fiberglass	3"	24	1200°F	120"
G703K-10GG	A	B	C	K	Fiberglass	3"	24	1650°F	120"
G703T-10GG	A	B	C	T	Fiberglass	3"	24	700°F	120"
G703J-30GG	A	B	C	J	Fiberglass	3"	24	1200°F	360"
G703K-30GG	A	B	C	K	Fiberglass	3"	24	1650°F	360"
G703T-30GG	A	B	C	T	Fiberglass	3"	24	700°F	360"
G706J-10GG	A	B	C	J	Fiberglass	6"	24	1200°F	120"
G706K-10GG	A	B	C	K	Fiberglass	6"	24	1650°F	120"
G706T-10GG	A	B	C	T	Fiberglass	6"	24	700°F	120"
G706J-30GG	A	B	C	J	Fiberglass	6"	24	1200°F	360"
G706K-30GG	A	B	C	K	Fiberglass	6"	24	1650°F	360"
G706T-30GG	A	B	C	T	Fiberglass	6"	24	700°F	360"
G712J-10GG	A	B	C	J	Fiberglass	12"	24	1200°F	120"
G712K-10GG	A	B	C	K	Fiberglass	12"	24	1650°F	120"
G712J-30GG	A	B	C	J	Fiberglass	12"	24	1200°F	360"
G712K-30GG	A	B	C	K	Fiberglass	12"	24	1650°F	360"
G712T-30GG	A	B	C	T	Fiberglass	12"	24	700°F	360"
G718J-10GG	A	B	C	J	Fiberglass	18"	24	1200°F	120"
G718K-10GG	A	B	C	K	Fiberglass	18"	24	1650°F	120"
G718J-30GG	A	B	C	J	Fiberglass	18"	24	1200°F	360"
G718K-30GG	A	B	C	K	Fiberglass	18"	24	1650°F	360"
G718T-30GG	A	B	C	T	Fiberglass	18"	24	700°F	360"

Teflon® Leadwire Thermocouples (500°F)

SERIES NUMBER	PROBE DIAMETER			CALIB.	LEADWIRE INSULATION	PROBE LENGTH "L"	GAUGE SIZE	SHEATH TEMP.	LEADWIRE LENGTH (B)
	1/8	3/16	1/4						
G703J-30ETT	A	B	C	J	Teflon®	3"	24	1200°F	360"
G703T-30ETT	A	B	C	T	Teflon®	3"	24	700°F	360"
G706J-30ETT	A	B	C	J	Teflon®	6"	24	1200°F	360"
G706T-30ETT	A	B	C	T	Teflon®	6"	24	700°F	360"
G712J-30ETT	A	B	C	J	Teflon®	12"	24	1200°F	360"
G712T-30ETT	A	B	C	T	Teflon®	12"	24	700°F	360"
G718J-30ETT	A	B	C	J	Teflon®	18"	24	1200°F	360"
G718T-30ETT	A	B	C	T	Teflon®	18"	24	700°F	360"

- Teflon® Leadwire
- 316SS Sheath
- Ungrounded Junction
- MgO Filled
- Field Bendable
- Moisture Resistant
- Special Limits of Error
- 600°F Transition Temp.

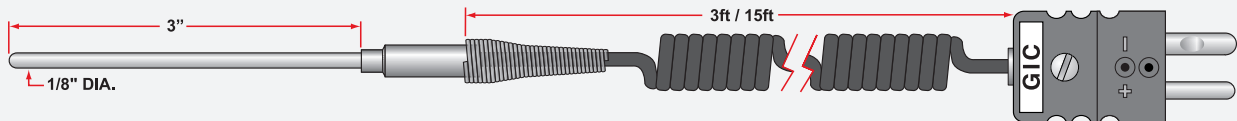

Polyvinyl Expandable Lead Thermocouples

SERIES NUMBER	PROBE DIA.	CALIB.	SHEATH MATERIAL	LEADWIRE INSULATION	PROBE LENGTH	LEADWIRE LENGTH
C703J COIL	0.125"	J	316SS	Polyvinyl	3"	180"

® Teflon® is a registered trademark

Armor Protected Thermocouples

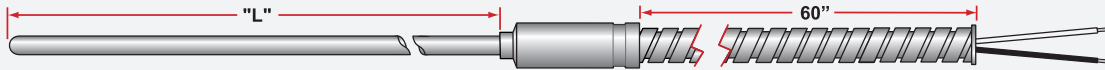

SERIES NUMBER	PROBE DIAMETER			CALIB.	ARMOR LENGTH	WIRE GAUGE	SHEATH TEMP.	PROBE LENGTH "L"
	1/8	3/16	1/4					
G806J	A	B	C	J	60"	24	1200°F	6"
G806K	A	B	C	K	60"	24	1650°F	6"
G812J	A	B	C	J	60"	24	1200°F	12"
G812K	A	B	C	K	60"	24	1650°F	12"
G818J	A	B	C	J	60"	24	1200°F	18"
G818K	A	B	C	K	60"	24	1650°F	18"

- Stainless Steel Flexible Armor
- 316SS Sheath
- MgO Filled
- Field Bendable
- Ungrounded Junction
- Sealed Transition (600°F)
- Fiberglass Leadwire (900°F)
- Special Limits of Error

Quick Disconnect Thermocouples

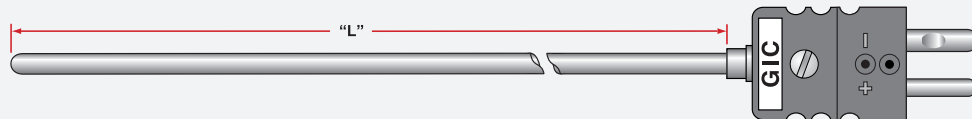

SERIES NUMBER	PROBE DIAMETER			CALIB.	SHEATH TEMP.	PROBE LENGTH "L"
	1/8	3/16	1/4			
G506J	A	B	C	J	1200°F	6"
G506K	A	B	C	K	1650°F	6"
G506T	A	B	C	T	700°F	6"
G512J	A	B	C	J	1200°F	12"
G512K	A	B	C	K	1650°F	12"
G512T	A	B	C	T	700°F	12"
G518J	A	B	C	J	1200°F	18"
G518K	A	B	C	K	1650°F	18"
G518T	A	B	C	T	700°F	18"

- Brazing Adapter for Durability
- Standard Male Plug (400°F Continuous)
- Ungrounded Junction
- Special Limits of Error
- MgO Filled
- Field Bendable
- 316SS Sheath

How to Order

Select the Series Number and designated letter for the appropriate sheath diameter. Example: Type J thermocouple with a 6" x 3/16" diameter probe is Part Number: G506J-B.

Reduced Tip Thermocouples

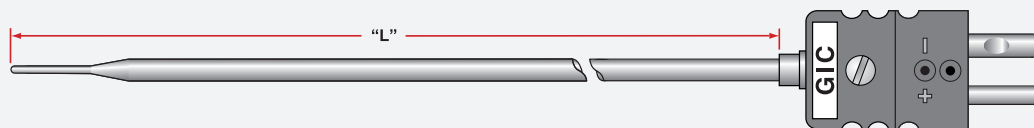

SERIES NUMBER	PROBE DIA.	CALIB.	SHEATH MATERIAL	SHEATH TEMP.	PROBE LENGTH
G506J-RT	0.125"	J	316SS	1200°F	6"
G506K-RT	0.125"	K	316SS	1650°F	6"

Durability of a 1/8" Diameter MgO Filled Probe, with a 1/16" Tip for **FAST RESPONSE!**

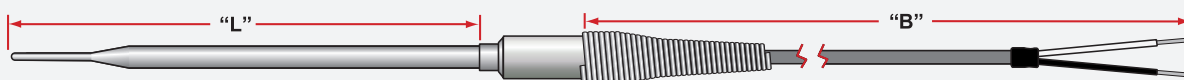

SERIES NUMBER	PROBE DIA.	CALIB.	SHEATH MATERIAL	PROBE LENGTH "L"	WIRE GAUGE	LEADWIRE LENGTH "B"	SHEATH TEMP.	LEADWIRE INSULATION
G706J-RT	0.125"	J	316SS	6"	24	120"	1200°F	Fiberglass
G706K-RT	0.125"	K	316SS	6"	24	120"	1650°F	Fiberglass

INDUSTRIAL HEAD THERMOCOUPLES

Industrial Head Thermocouples

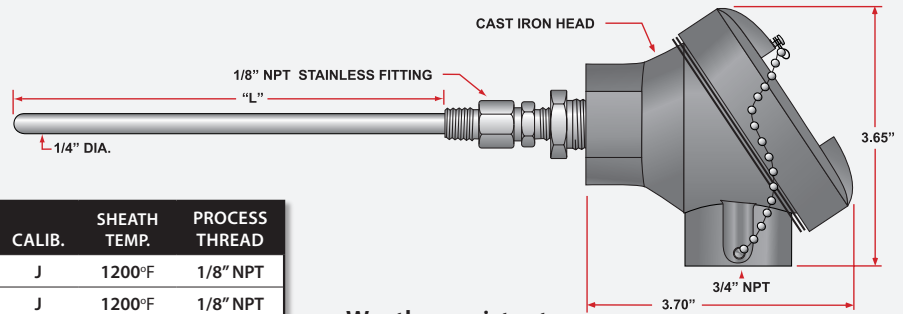

Industrial Head T/C Cast Iron

SERIES NUMBER	PROBE LENGTH "L"	PROBE DIA.	SHEATH MATERIAL	CALIB.	SHEATH TEMP.	PROCESS THREAD
G903J-CI	3"	0.25"	316SS	J	1200°F	1/8" NPT
G906J-CI	6"	0.25"	316SS	J	1200°F	1/8" NPT
G912J-CI	12"	0.25"	316SS	J	1200°F	1/8" NPT
G906K-CI	6"	0.25"	316SS	K	1650°F	1/8" NPT
G912K-CI	12"	0.25"	316SS	K	1650°F	1/8" NPT

- Weather resistant
- 1/4" DIA. Probe
- Special Limits of Error
- Sturdy 2 Piece Cast Iron Head for Rugged Industrial Applications

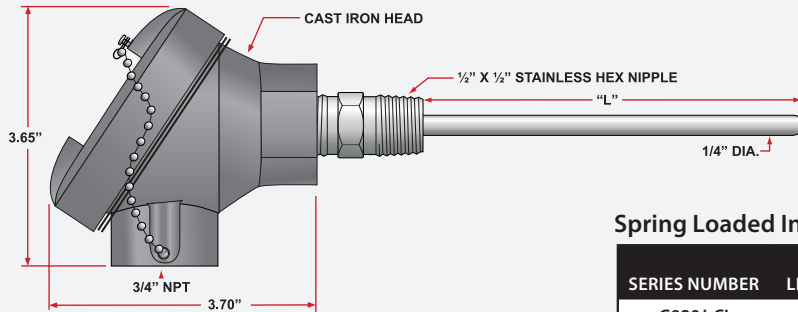

Spring Loaded Design is made to be used with a thermowell. The spring keeps the probe tight against the well bottom for a more precise reading.

Spring Loaded Industrial Head T/C Cast Iron

SERIES NUMBER	PROBE LENGTH "L"	PROBE DIA.	SHEATH MATERIAL	CALIB.	SHEATH TEMP.	PROCESS THREAD
G920J-CI	3.75"	0.25"	304SS	J	1200°F	1/2" NPT
G920K-CI	3.75"	0.25"	304SS	K	1650°F	1/2" NPT
G920T-CI	3.75"	0.25"	304SS	T	1400°F	1/2" NPT
G921J-CI	5.75"	0.25"	304SS	J	1200°F	1/2" NPT
G921K-CI	5.75"	0.25"	304SS	K	1650°F	1/2" NPT
G921T-CI	5.75"	0.25"	304SS	T	1400°F	1/2" NPT
G922J-CI	8.75"	0.25"	304SS	J	1200°F	1/2" NPT
G922K-CI	8.75"	0.25"	304SS	K	1650°F	1/2" NPT
G922T-CI	8.75"	0.25"	304SS	T	1400°F	1/2" NPT

Industrial Head T/C Aluminum

SERIES NUMBER	PROBE LENGTH "L"	PROBE DIA.	SHEATH MATERIAL	CALIB.	SHEATH TEMP.	PROCESS THREAD
G906J-AL	6"	0.25"	316SS	J	1200°F	1/2" NPT
G906K-AL	6"	0.25"	316SS	K	1650°F	1/2" NPT
G912J-AL	12"	0.25"	316SS	J	1200°F	1/2" NPT
G912K-AL	12"	0.25"	316SS	K	1650°F	1/2" NPT
G918J-AL	18"	0.25"	316SS	J	1200°F	1/2" NPT
G918K-AL	18"	0.25"	316SS	K	1650°F	1/2" NPT

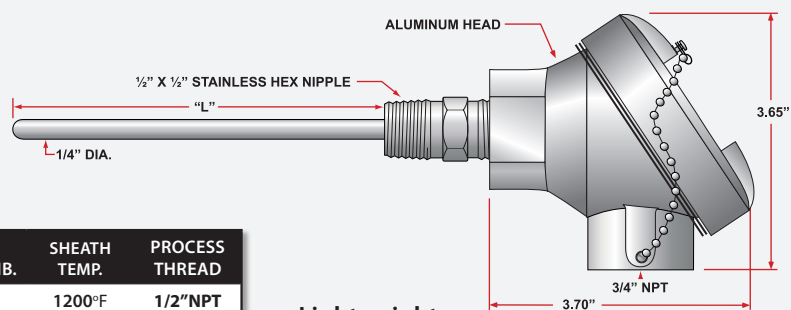

- Lightweight
- Weather resistant
- 1/4" DIA. Probe
- Welded fitting
- Special Limits of Error

SPECIALTY THERMOCOUPLES (for Plastic Extruders)

Melt Bolt Thermocouple

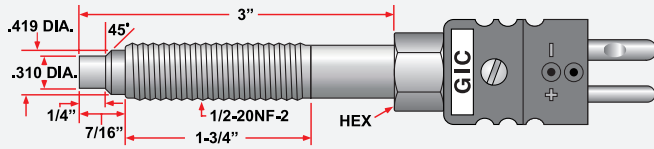

Rigid Bolt Thermocouple

SERIES NUMBER	CALIB.	BOLT MATERIAL	JUNCTION	MAX. TEMP.
G300J	J	303SS	GROUND	1200F

Flexible Armored Bolt Thermocouple

SERIES NUMBER	CALIB.	BOLT MATERIAL	LEADWIRE LENGTH	JUNCTION	MAX. TEMP.
G200J	J	303SS	24"	GROUND	900F

Designed for direct insertion into the melt stream to provide an accurate measurement.

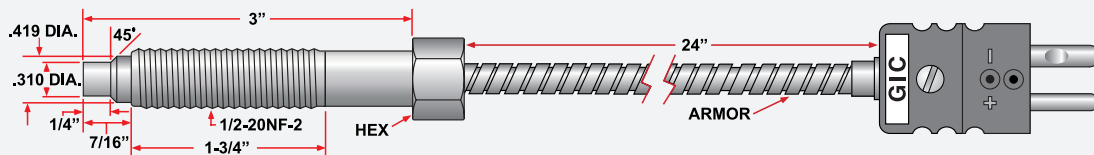

BAYONET LOCKCAP STYLE THERMOCOUPLES

Bayonet Lockcap Thermocouple



- Heavy Duty
- Weather resistant
- Special Limits of Error

Fixed Bayonet Lockcap Thermocouple

SERIES NUMBER	PROBE DIA.	CALIB.	SHEATH MATERIAL	PROBE LENGTH	LEADWIRE LENGTH	LEADWIRE INSULATION	SHIELD	WIRE GAUGE	MAX. TEMP.
G600J	0.188"	J	304SS	3.125"	30"	Fiberglass	SS Armor	20 Strd.	900F



Adjustable Depth Bayonet Lockcap Thermocouples (Armor)

SERIES NUMBER	PROBE DIA.	CALIB.	SHEATH MATERIAL	PROBE LENGTH	SPRING LENGTH	LEADWIRE INSULATION	SHIELDING	WIRE GAUGE
G603J-ALCAR	0.188	J	304SS	0.25"	36"	Fiberglass	SS Armor	20 Strd.

- Bendable
- Armored Leads
- Special Limits of Error



Adjustable Depth Bayonet Lockcap Thermocouples (Spring)

SERIES NUMBER	PROBE DIA.	CALIB.	SHEATH MATERIAL	PROBE LENGTH	SPRING LENGTH	LEADWIRE INSULATION	SHIELDING	WIRE GAUGE	MAX. TEMP.
G601J-ALC06	0.188	J	304SS	0.25"	6"	Fiberglass	SS Overbraid	20 Strd.	900F
G602J-ALC12	0.188	J	304SS	0.25"	12"	Fiberglass	SS Overbraid	20 Strd.	900F

- Bendable
- Stainless Overbraid
- Special Limits of Error
- Eliminates Large Inventory of Fixed Designs

GIC Stock Sensors

ECONOMY THERMOCOUPLES

Insulated Wire Thermocouples



SERIES NUMBER	CALIBRATION	LEADWIRE LENGTH "A"	LEADWIRE INSULATION	MAXIMUM TEMP.	WIRE GAUGE
G100J-IW	Type J	72"	Fiberglass	900 F	20 Ga.
G100K-IW	Type K	72"	Fiberglass	900 F	20 Ga.
G101J-IW	Type J	72"	Teflon®	500 F	20 Ga.
G101T-IW	Type T	72"	Teflon®	500 F	20 Ga.

- Welded junction for best T/C contact
- Sold in packets of 5
- Teflon® or fiberglass insulation

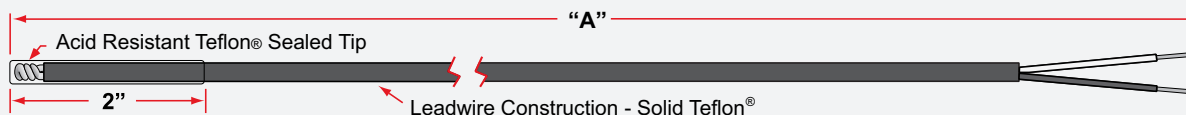

Acid Resistant Thermocouples

SERIES NUMBER	CALIBRATION	LEADWIRE LENGTH "A"	LEADWIRE INSULATION	MAXIMUM TEMP.	WIRE GAUGE
G415J	Type J	180"	Teflon®	500 F	20 Ga.
G416T	Type T	180"	Teflon®	500 F	20 Ga.

- For Measurement in Low Concentration Acid Baths
- "Surface Mount" Design
- Completely Submersible

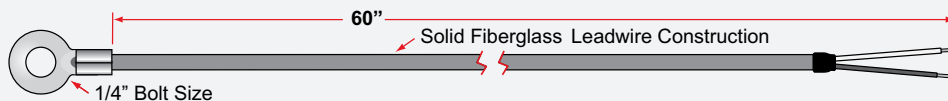

Washer Thermocouples

SERIES NUMBER	CALIBRATION	LEADWIRE LENGTH	LEADWIRE INSULATION	MAXIMUM TEMP.	WIRE GAUGE
G400J	Type J	60"	Fiberglass	900 F	20 Ga.
G400K	Type K	60"	Fiberglass	900 F	20 Ga.

- "Surface Mount" Design
- Attach with Bolt or #10 Screw
- Stainless Overbraid
- Special Limits of Error
- High Temp Nickel Washer

RTD'S

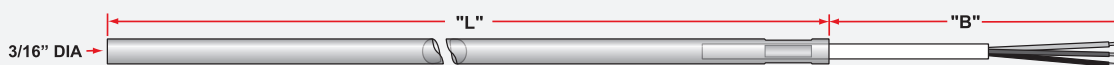

- 0.1% Element Accuracy
- 3-Wire Teflon® Insulated Leads
- .00385 Ohm/Ohm/°C "DIN" Curve
- Rated for Applications to 500°F

SERIES NUMBER	PROBE LENGTH "L"	PROBE DIA.	SHEATH MATERIAL	ELEMENT MATERIAL	ELEMENT RESISTANCE	LEADWIRE LENGTH "B"	WIRE GAUGE
GB106	6"	0.188"	316SS	Platinum	100 Ohms	240"	26
GB112	12"	0.188"	316SS	Platinum	100 Ohms	240"	26
GB118	18"	0.188"	316SS	Platinum	100 Ohms	240"	26

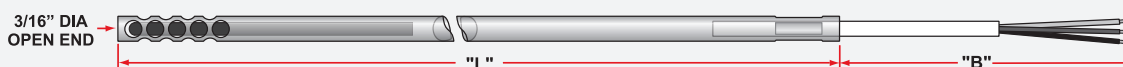

- Vented Tip for a Fast Response in Air
- Air Duct & Environmental Chamber
- Rated for Applications to 500°F

Ventilated RTD Assembly

SERIES NUMBER	PROBE LENGTH "L"	PROBE DIA.	SHEATH MATERIAL	ELEMENT MATERIAL	ELEMENT RESISTANCE	LEADWIRE LENGTH "B"	WIRE GAUGE
GB112-20-VNT	12"	0.188"	304SS	Platinum	100 Ohms	240"	26

RTD ASSEMBLIES

Industrial Head RTD Assemblies

- .00385 Ohm/Ohm/°C Temperature Coeff.
- Rated for Applications to 500°F
- Welded Fitting
- 3-Wire Design

Industrial Head RTD (Aluminum)

SERIES NUMBER	PROBE LENGTH "L"	PROBE DIA.	SHEATH MATERIAL	ELEMENT MATERIAL	ELEMENT RESISTANCE	PROCESS THREAD
G906-RTD-AL	6"	0.25"	316SS	Platinum	100 Ohms	1/2"NPT
G912-RTD-AL	12"	0.25"	316SS	Platinum	100 Ohms	1/2"NPT
G918-RTD-AL	18"	0.25"	316SS	Platinum	100 Ohms	1/2"NPT </td

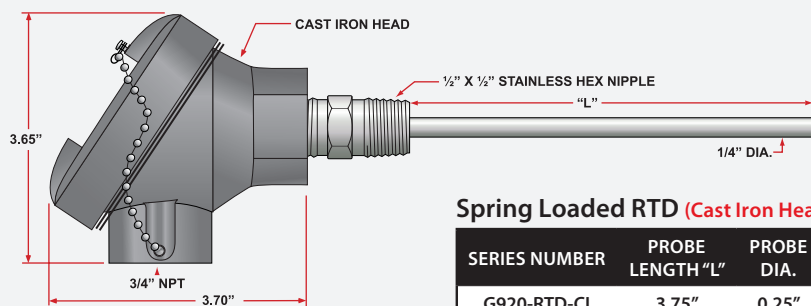
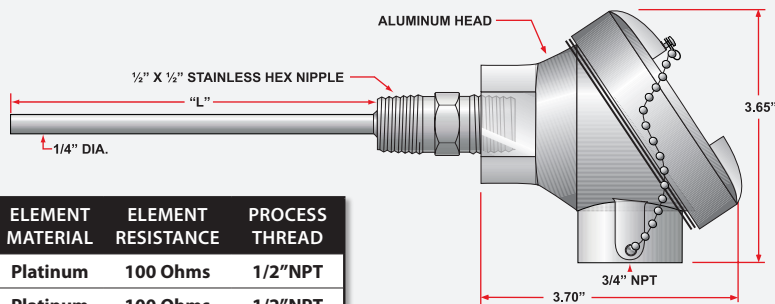

Spring Loaded RTD (Cast Iron Head)

SERIES NUMBER	PROBE LENGTH "L"	PROBE DIA.	SHEATH MATERIAL	ELEMENT MATERIAL	ELEMENT RESISTANCE	PROCESS THREAD
G920-RTD-CI	3.75"	0.25"	316SS	Platinum	100 Ohms	1/2"NPT
G921-RTD-CI	5.75"	0.25"	316SS	Platinum	100 Ohms	1/2"NPT
G922-RTD-CI	8.75"	0.25"	316SS	Platinum	100 Ohms	1/2"NPT

- For Use in Applications Requiring a Thermowell
- Rated for Applications to 500°F
- Spring Loaded for Best Contact
- 3-Wire Design

ACCESSORIES

For a larger selection of Accessories go to www.GICThermodynamics.com

Bayonet Fittings (Nickel plated steel)

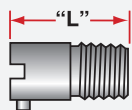

SERIES NUMBER	LENGTH (L)	THREAD SIZE
G95	.875"	1/8" NPT
G95L	1.375"	1/8" NPT
G95XL	3.875"	1/8" NPT

Adjustable Bayonet w/ Lockcap & Spring

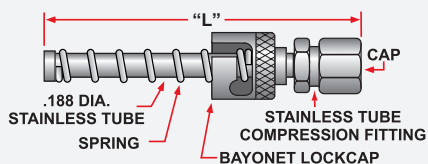

SERIES NUMBER	LENGTH (L)	GLAND MATERIAL	TEMP RATING
G4561-SS	2.875"	STAINLESS	1000 F
G4761-L	2.625"	LAVA	1000 F
G4761-T	2.625"	Teflon®	400 F

The adjustable bayonet turns a 1/8" dia. probe into a spring loaded assembly. The compression fitting design eliminates the need for any brazing, and offers a choice of stainless steel glands for high pressure one time adjustment or lava and Teflon® glands that allow repeated adjustments.

Stainless Steel Compression Fittings

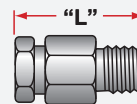

Readjustable (Neoprene Gland)

SERIES NUMBER	LENGTH (L)	THREAD SIZE	PSI	MAX TEMP.
G47N125	1.25"	1/8" NPT	3000	200 F
G47N188	1.25"	1/8" NPT	3000	200 F

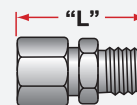

One Time Adjustment (Stainless Ferrule)

SERIES NUMBER	LENGTH (L)	THREAD SIZE	PSI	MAX TEMP.
G45-063	1.25"	1/8" NPT	10000	1000 F
G45-125	1.25"	1/8" NPT	10000	1000 F
G45-188	1.3125"	1/8" NPT	10000	1000 F
G45-250	1.3125"	1/8" NPT	10000	1000 F
G44-125	1.375"	1/4" NPT	10000	1000 F
G44-188	1.4375"	1/4" NPT	10000	1000 F

GIC Stock Sensors

Stock Thermowells

- Standard Threaded Wells 1/2" NPT & 3/4" NPT Process Thread
- Bored for 1/4" Diameter Elements
- For use with Spring Loaded RTD's and Thermocouples (See Stock Series G920's)

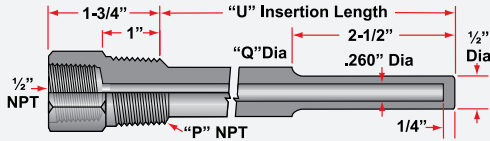

SERIES NUMBER	INSERTION LENGTH (U)	PROCESS THREAD	THERMOWELL MATERIAL	DIAMETER (Q)	USE WITH STOCK PROBE
WTS-260B-04N-N-4	2.5"	3/4" NPT	304SS	3/4"	G920
WTS-260B-04N-N-6	2.5"	3/4" NPT	316SS	3/4"	G920
WTS-260B-06N-N-4	4.5"	3/4" NPT	304SS	3/4"	G921
WTS-260B-06N-N-6	4.5"	3/4" NPT	316SS	3/4"	G921
WTS-260B-09N-N-4	7.5"	3/4" NPT	304SS	3/4"	G922
WTS-260B-09N-N-6	7.5"	3/4" NPT	316SS	3/4"	G922
WTS-260A-04N-N-4	2.5"	1/2" NPT	304SS	5/8"	G920
WTS-260A-04N-N-6	2.5"	1/2" NPT	316SS	5/8"	G920
WTS-260A-06N-N-4	4.5"	1/2" NPT	304SS	5/8"	G921
WTS-260A-06N-N-6	4.5"	1/2" NPT	316SS	5/8"	G921
WTS-260A-09N-N-4	7.5"	1/2" NPT	304SS	5/8"	G922
WTS-260A-09N-N-6	7.5"	1/2" NPT	316SS	5/8"	G922

Miniature Protection Tube

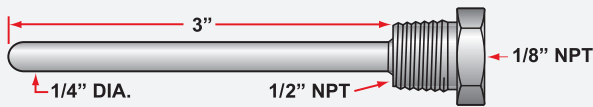

SERIES NUMBER	INSERTION LENGTH (U)	PROCESS THREAD	SHEATH MATERIAL
MPT-3	3"	1/2" NPT	304SS
MPT-6	6"	1/2" NPT	304SS

- For use with 1/8" and 3/16" Diameter Probes

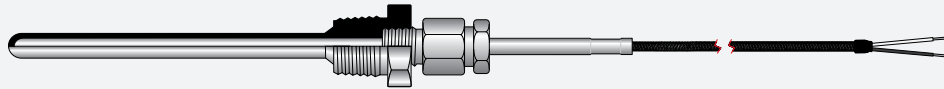

Shown Here with a Style GP Probe and a Stock G47 compression fitting

Stock Standard Connectors - Jab In

- Glass filled thermoplastic for high impact strength
- Rated for 400 F continuous temperature
- Color coded for easy identification
- Accept wire up to 14 gauge

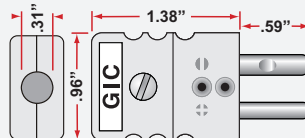
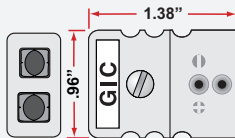

CATALOG #	CALIB.
JPSH-NN	J
KPSH-NN	K
TPSH-NN	T
EPSH-NN	E
JJSH-NN	J
KJSH-NN	K
TJSH-NN	T
EJSH-NN	E

Stock Miniature Connectors

- Provides quick connection of fine thermocouple wires
- Rated for 400 F continuous temperature
- Color coded for easy identification
- Accept wire from 36 to 20 gauge

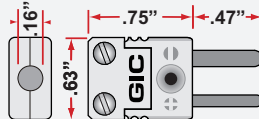
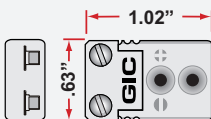

CATALOG #	CALIB.
JMSS-NN	J
KMSS-NN	K
TMSS-NN	T
EMSS-NN	E
JFSS-NN	J
KFSS-NN	K
TFSS-NN	T
EFSS-NN	E

GIC carries a variety of thermocouple wire in stock in pre-spooled lengths of 50, 100, 250, 500 and 1000 foot. Special construction wire can be provided, in minimum 2000 foot lengths, upon request.

Stock Spooled Thermocouple Wire

Type J

CALIB.	SERIES	GAUGE	COND. SIZE	TYPE OF WIRE	LEADWIRE INSULATION	SPOOL LENGTH	MAX REC. TEMP (F)
J	GJG50	20	0.032	Solid	FIBERGLASS	50 FT	900 F
J	GJG100	20	0.032	Solid	FIBERGLASS	100 FT	900 F
J	GJG250	20	0.032	Solid	FIBERGLASS	250 FT	900 F
J	GJG500	20	0.032	Solid	FIBERGLASS	500 FT	900 F
J	GJG1000	20	0.032	Solid	FIBERGLASS	1000 FT	900 F
J	GJT50	20	0.032	Solid	TEFLON®	50 FT	500 F
J	GJT100	20	0.032	Solid	TEFLON®	100 FT	500 F
J	GJT250	20	0.032	Solid	TEFLON®	250 FT	500 F
J	GJT500	20	0.032	Solid	TEFLON®	500 FT	500 F
J	GJT1000	20	0.032	Solid	TEFLON®	1000 FT	500 F
J	GFJT100	20	0.032	Stranded	TEFLON®	100 FT	500 F
J	GFJT250	20	0.032	Stranded	TEFLON®	250 FT	500 F
J	GFJT500	20	0.032	Stranded	TEFLON®	500 FT	500 F
J	GFJT1000	20	0.032	Stranded	TEFLON®	1000 FT	500 F
J	GJ24T100	24	0.020	Solid	TEFLON®	100 FT	500 F
J	GJ24T250	24	0.020	Solid	TEFLON®	250 FT	500 F
J	GJ24T500	24	0.020	Solid	TEFLON®	500 FT	500 F
J	GJ24T1000	24	0.020	Solid	TEFLON®	1000 FT	500 F

Type K

CALIB.	SERIES	GAUGE	COND. SIZE	TYPE OF WIRE	LEADWIRE INSULATION	SPOOL LENGTH	MAX REC. TEMP (F)
K	GKG50	20	0.032	Solid	FIBERGLASS	50 FT	900 F
K	GKG100	20	0.032	Solid	FIBERGLASS	100 FT	900 F
K	GKG250	20	0.032	Solid	FIBERGLASS	250 FT	900 F
K	GKG500	20	0.032	Solid	FIBERGLASS	500 FT	900 F
K	GKG1000	20	0.032	Solid	FIBERGLASS	1000 FT	900 F
K	GKT100	20	0.032	Solid	TEFLON®	50 FT	500 F
K	GKT500	20	0.032	Solid	TEFLON®	500 FT	500 F
K	GKT1000	20	0.032	Solid	TEFLON®	1000 FT	500 F
K	GFKG100	20	0.032	Stranded	FIBERGLASS	100 FT	900 F
K	GFKG250	20	0.032	Stranded	FIBERGLASS	250 FT	900 F
K	GFKG500	20	0.032	Stranded	FIBERGLASS	500 FT	900 F
K	GFKG1000	20	0.032	Stranded	FIBERGLASS	1000 FT	900 F
K	GK24G100	24	0.020	Solid	FIBERGLASS	100 FT	900 F
K	GK24G250	24	0.020	Solid	FIBERGLASS	250 FT	900 F
K	GK24G500	24	0.020	Solid	FIBERGLASS	500 FT	900 F
K	GK24G1000	24	0.020	Solid	FIBERGLASS	1000 FT	900 F

Type T

CALIB.	SERIES	GAUGE	COND. SIZE	TYPE OF WIRE	LEADWIRE INSULATION	SPOOL LENGTH	MAX REC. TEMP (F)
T	GTT50	20	0.032	Solid	TEFLON®	50 FT	500 F
T	GTT100	20	0.032	Solid	TEFLON®	100 FT	500 F
T	GTT250	20	0.032	Solid	TEFLON®	250 FT	500 F
T	GTT500	20	0.032	Solid	TEFLON®	500 FT	500 F
T	GTT1000	20	0.032	Solid	TEFLON®	1000 FT	500 F

Thermocouple Assemblies

When It Comes to Thermocouples “There IS a Difference”!

Thermocouples are the most common and versatile sensors used to measure temperature. They can be designed to work in any application where a temperature measurement is required ranging from minus 300 °F to over 4000 °F.

Thermocouples operate on the principle of thermal emf (Electromotive Force). Thomas Seebeck observed in 1821 that two dissimilar metal wires, if joined at both ends, produce a current when the junctions are at different temperatures. The current produced is a function of the junction temperature and the type of metals used. This relationship between thermal emf and temperature is now known as the Seebeck effect.

The thermal emf can be measured by breaking the thermocouple loop at any point and measuring the open circuit voltage. For example, a thermocouple, made of Chromel/Alumel metals (Type K) generates about 40 microvolts per degree Celsius.

The voltage/temperature relationship varies depending on the metals used. The metal combinations used depend on the output voltage required and the temperature range monitored. ANSI Thermocouples are tested and graded against the American National Standards Institute standards and are available in Standard and Special Limits grades (see table below). The Special Limits grade has only half the error of the Standard grade and is recommended for high temperature applications.

Thermocouples are considered to be “tip sensitive” because they measure temperature at the junction, which is located at the end or tip of the sensor. Care should be given when considering the best assembly to fit an application. To acquire accurate temperature readings, careful consideration should be given to the design and sensor location in the process. (See inside back cover for “Thermocouple Installation & Maintenance Suggestions”)

GIC Thermodynamics’ sales and engineering staff will assist you with designing the best thermocouple sensor style to fit your process and application. Selecting the proper sensor style is very important, as each application or process has its own specific inherent problems that require careful consideration in order to determine the sensors life, accuracy, and dependability. When choosing a sensor it is important to consider its location, temperature range, accuracy required, how rapidly the temperature cycles, heat conduction, process environment, vibration, and ease of installation. If you need additional assistance with the selection of a sensor for your application, please feel free to contact our sales and engineering staff.

ANSI Conductor Characteristics: Temperature & Limits of Error

ISA CODE	CONDUCTOR & CHARACTERISTICS		TEMPERATURE RANGE (F)	SINGLE CONDUCTOR COLOR CODE	LIMITS OF ERROR		APPLICATION NOTES
	POSITIVE	NEGATIVE			STANDARD	SPECIAL	
J	Iron (magnetic)	Constantan (non-magnetic)	0 to 530 F 530 to 1400 F	J+ White J- Red	+/- 4F +/- 3/4%	+/- 2F +/- 3/8%	Reducing atmosphere recommended. Iron oxides rapidly at elevated temperatures.
T	Copper (non-magnetic)	Constantan (non-magnetic)	-75 to 200 F 200 to 700 F	T+ Blue T- Red	+/- 1-1/2F +/- 3/4%	+/- 3/4F +/- 3/8%	Can be used in oxidizing or reducing atmospheres rust and corrosion resistant. Fine for Cryogenic.
K	Chromel (non-magnetic)	Alumel (magnetic)	0 to 530 F 530 to 2300 F	K+ Yellow K- Red	+/- 4F +/- 3/4%	+/- 2F +/- 3/8%	Oxidizing atmosphere recommended. Vented protection tube suggested in reducing atmosphere.
E	Chromel (non-magnetic)	Constantan (non-magnetic)	0 to 600 F 600 to 1600 F	E+ Purple E- Red	+/- 3F +/- 1/2%	+/- 3/8%	Oxidizing atmosphere recommended. Highest emf output of thermocouples commonly used.
S	Platinum 10% Rhodium (non-magnetic)	Platinum (non-magnetic)	0 to 1200 F 1200 to 2700 F	E+ Orange E- Red	+/- 5F +/- 1/2%	+/- 2-1/2F +/- 1/4%	Oxidizing atmosphere recommended. Easily contaminated. The accepted laboratory standard in premium grade due to its reproducibility.
R	Platinum 13% Rhodium (non-magnetic)	Platinum (non-magnetic)	0 to 1200 F 1200 to 2700 F	N+ Black N- Red	+/- 3F +/- 1/4%	+/- 1F +/- 1/10%	Same conditions as 10% above but has 13% Rhodium slightly higher emf. Mostly used in industrial apps.
N	Nicrosil (non-magnetic)	Nisil (non-magnetic)	0 to 530 F 530 to 2300 F	S+ Black S- Red	+/- 4F +/- 3/4%	+/- 2F +/- 3/8%	Better Resistance to Oxidation and longer life at high temperatures than Type K.
B	Platinum 30% Rhodium	Platinum	1000 to 3200 F	B+ Grey B- Red	+/- 1/2%	+/- 1/2%	Can be used in a vacuum with limited life.

Special Note:

Certain characteristics and tolerances of thermocouple materials change over time and usage, including the emf vs Temperature relationship. As a result of these changes, it is not recommended to recalibrate used sensors once they are out of tolerance. The useful life of a thermocouple depends on several factors including wire gauge, environment and temperature range. For longer sensor life, we recommend using the largest diameter probe possible. But consider the larger the diameter the slower the response time (See Approximate MgO Response time chart on page 13).

Mineral Insulated (MgO) Thermocouples

Magnesium Oxide (MgO) Insulated Thermocouples

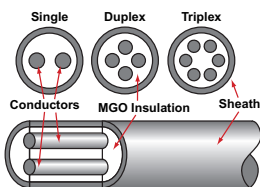

MgO thermocouples offer the greatest variety of features of all styles of thermocouples making them the best choice for most applications. They are made in all calibrations with a wide variety of sheath diameters and materials. MgO assemblies are fully annealed and field bendable. They can be bent to a minimum radius of twice the sheath diameter without damage to the insulation and mounting hardware can be brazed or welded to the sheath.

MgO sensors are recommended where a moisture proof, non-porous insulation is required and for applications where high pressure, high vibration and high temperature conditions are encountered. These variations make them the logical choice for applications from test labs to heavy industry.

GIC uses only High Purity MgO in our assemblies which is recommended for high temperature applications. MgO filled metal insulated thermocouples are available in sizes from 0.010 to 0.500 inch diameters. Choosing the proper diameter for an application depends on the process environment, process temperatures, and desired response time. A good rule to consider is the higher the temperature, the larger the diameter probe. Also, the faster the response time required, the smaller the diameter, providing high temperatures are not involved. For ungrounded sensors with a faster response time see GIC's new "Faster Response Time" at www.gicsensors.com.

Approximate MgO Response times

MgO Diameter	Grounded Junction	Ungrounded Junction
.020	.10 Sec.	.40 Sec.
.032	.14 Sec.	.50 Sec.
.040	.19 Sec.	.65 Sec.
.063	.22 Sec.	.75 Sec.
.090	.37 Sec.	.88 Sec.
.125	.52 Sec.	1.25 Sec.
.188	1.00 Sec.	2.40 Sec.
.250	2.20 Sec.	4.30 Sec.
20 Gauge Bare wire	.45 Sec.	-
14 Gauge Bare wire	.50 Sec.	-

Diagram SM

Sheath Materials

The sheath material gives the MgO insulation its protection from the environment, contamination and potential mechanical damage. There is no material that is appropriate for all applications; you must consider the process temperature, corrosiveness, mechanical strength, cost and intended service life when selecting the material.

- **304SS (4)** maximum temperature is 1650°F (900°C). It is most often used in low temperature processes and is the lowest cost of the stainless steels. Widely used in beverage, food, chemical and other industries where mild corrosion resistance is needed. It is susceptible to carbide precipitation at temperatures of 900 to 1600°F (480 to 870°C).
- **310SS (0)** maximum temperature is 2100°F (900°C). It contains 25% Chromium and 20% Nickel. Its corrosion resistance and mechanical strength is similar to 304SS but slightly better, has good heat resistance but not as ductile as the 304 stainless steel.
- **316SS (6)** maximum temperature is 1700°F (900°C). It has the best corrosion resistance of all the stainless steel grades. It is susceptible to carbide precipitation at temperatures of 900 to 1600°F (480 to 870°C). It is widely used in the chemical and food industry.
- **Inconel 600 (I)** maximum temperature is 2100°F (1175°C). It is the most predominately used sheath material due to it's high temperature strength, resistance to chloride ion stress, corrosion resistance, oxidation resistance at elevated temperatures and it fairs well in nitriding environments. Inconel 600 must not be used in sulfur bearing environments.
- **Monel (M)** maximum temperature is 1000°F (540°C). Nickel-copper alloy. Excellent resistance to salt water, sulfuric acid, hydrofluoric acid, hydrochloric acid and most alkalis.
- **Hastelloy® X (I)** maximum temperature is 2200°F (1205°C). Resistant to reducing, oxidizing and neutral atmospheric conditions. Superior high temperature strength and excellent oxidizing resistance.

Other sheath materials are available for special applications. **446 SS (X)**, **Copper (C)**, **Epoxy Glass Sheath (T)** (to be used with Cooper Tipped sensors). Plus high temperature materials - **Tantalum (T)**, **Molybdenum**, **Platinum**, **Aluminum Oxide**, and **Graphite**. Please consult the factory for your special request. For a complete list of sheath materials, go to our website at www.gicsensors.com.

Diagram MgO

RECOMMENDED SHEATH MATERIALS (MgO)			
MATERIAL	MAX IN AIR (°F)	OPERATING ATMOSPHERE	MAX CONTINUOUS TEMPERATURE (°F)
304 Stainless	1900	ORNV	1650
310 Stainless	2550	ORNV	2100
316 Stainless	2500	ORNV	1700
INCONEL	2550	ONV^b	2100
O = Oxidizing N = Neutral		R = Reducing V = Vacuum	V ^b = Very sensitive to sulfur corrosion

Thermocouple Tip Styles

Round Tip is the standard tip provided unless otherwise specified. It can be used in an open atmosphere, in a thermowell, in a liquid or air, and high pressures.

Flat Tip reduces the amount of "sheath" material at the tip of the probe, which can potentially affect the response time, less mass for thermal conduction into the thermocouple junction.

Drill Point Tip (118 deg tip) allows more of the tip surface to be in direct contact with the surface area of a hole, which normally has been "drilled" to the depth required, as opposed to being milled flat at the bottom.

Needle Tip is shaped to a fine point similar to a sewing needle. This facilitates the sensor tip to be inserted into an object for temperature measurement such as food processing or monitoring "skin" temperature on automobile tires at a test track. Not available in diameters below 1/16".

Reduced Tip sensor for 1/8" reduced to 1/16" (reduced section is 3/8" to 1.0") allows the "ruggedness" of the 1/8" diameter while giving the fast response of a 1/16" diameter probe. Alternative to a swaged reduced tip is a "step down" version of the reduced tip. This is facilitated by brazing or welding (depends on the diameter) a smaller diameter "MgO" thermocouple inside a larger diameter tube. This again allows the support or ruggedness of the larger diameter while maintaining the fast response of a smaller diameter sensor.

Exposed Tip is recommended where fast response is desired, and corrosive conditions are nonexistent. Commonly used in air and gas applications. The thermocouple wires are butt welded together and the insulation sealed against liquid or gas penetration into the magnesium oxide insulation. The normal exposed length is equal to 1½ times the diameter of the probe, it is not available in 0.010" diameter.

Vented Tip is an exposed junction tip design where the sensor is protected by a laser cut vented shield. Most commonly used on RTD's where fast response is desired in air and gas to protect the delicate element. It can also be used on Rigid Tube design thermocouples where the wire needs to be exposed and protected.

Diagram TS-TC









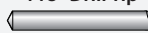

Junction Tip Style	Grounded Junction	Ungrounded Junction
Round Tip 	G(Std)	U
Flat Tip 	F	B
118° Drill Tip 	D	C
Needle Tip 	P	M
Reduced Tips 	R	Q
Exposed Tip 	-	E
Vented Tip 	-	V

Diagram JT

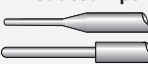
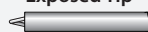
JUNCTION TYPES	
 <p>Grounded Junction the wires are welded securely into the closure end of the sheath, becoming an integral part of the junction. The response time is closest to the exposed type junction. Recommended in the presence of liquids, moisture, gas, or high pressures. The wire is adequately protected from corrosive or erosive conditions. Not recommended in 0.500" O.D.</p>	 <p>Ungrounded Junction the thermocouple junction is fully insulated from the welded sheath end. The response time is longer than a grounded junction. It is excellent for electrical applications where stray emf's would affect the reading, gives good noise isolation. It also is useful in applications where rapid or frequent temperature cycling occurs, and provides for longer service life of the sensor.</p>
 <p>Separate Ungrounded junction is only available for a duplex (or triplex) style MgO material. It gives your application the usefulness of two (three for triplex) separate junctions isolated from each other and the sheath, inside one protective sheath material. Offers the same benefits as the ungrounded junction of response time, junction isolation, allowing you to send a signal to a different location or for redundancy as a back up.</p>	 <p>Common Ungrounded junction is only available in duplex (or triplex) style MgO material. This is supplied with all the wires welded together separate from the sheath; the junction is isolated from the sheath but no isolation between the junctions. Offers similar benefits, response time, etc., as the separate ungrounded without the junction to junction isolation.</p>

Fittings (T/C and RTD's)



The fixed bayonet fitting with lockcap provides spring loaded pressure designed for holding probes in place without tapping or drilling. For use with .188" diameter probes only.

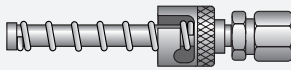

An adjustable bayonet compression fitting, designed for use with .125" probes, can be positioned at the time of installation. (Available from stock. See page 9)

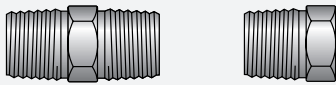

Fittings are brazed or welded to the sheath at the time of manufacture. Available in multiple bore sizes, threads (NPT and metric), materials and designs.

One time adj. Compression Fittings (Stainless Ferrule)

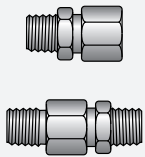

Fittings can be positioned to the exact length at the time of installation. The metal ferrules, brass or stainless, cannot be moved or repositioned once they are installed and compressed.

Readjustable Compression Fittings

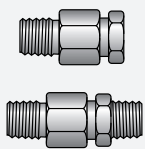

The use of various sealant gland materials allows the compression fitting to be repositioned several times after it has been installed. The glands are rated up to 3000 psi and the following temperatures:

*Teflon® gland (Standard) (400°F)
Neoprene gland (200°F) and Lava Gland (1200°F) Also available.

Flanges (T/C and RTD's)



GIC can provide any size flange, including custom designs, in large or small quantities. Fixed flanges can be welded or brazed on. Adjustable flanges are also available.

For complete list of Sheath Fittings, Transitions, Transition potting materials and specifications:

www.GICSensors.com

Transitions (Style F - T/C and RTD's)

Durable stainless tube which allows for the mechanical and electrical attachment of the lead wire to the metal sheathed, mineral insulated thermocouple or RTD probe. Standard potting is epoxy based and moisture resistant to 500°F. The Hi-Temp potting is ceramic based and good for temperatures to 1100°F. Custom configurations and compounds for extreme temperatures and conditions are also available.



A = Standard Transition w/Relief Spring (500°F)(Std)
C = Hi-Temp Transition w/Relief Spring (1100°F)



B = Standard Transition (500°F)
D = Hi-Temp Transition (1100°F)

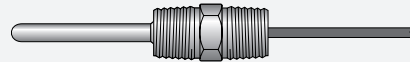

E = Hex Nipple Transition (500°F) Specify size.
F = Hi-Temp Hex Nipple (1100°F) Specify size.

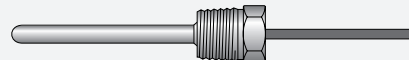

G = Bushing - Threads toward Tip (500°F) Specify size.
H = Hi-Temp Bushing - Threads toward Tip (1100°F) Specify size.

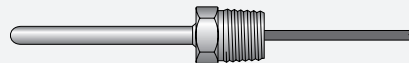

I = Bushing - Threads toward Leads (500°F) Specify size.
J = Hi-Temp Bushing - Threads toward Leads (1100°F) Specify size.



K = Smooth Transition (500°F)
L = Hi-Temp Smooth Transition (1100°F)



M = Mini-Transition (500°F)
O = Hi-Temp Mini Transition (1100°F)

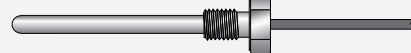

P = Bolt Transition - Threads toward Tip (500°F) Specify size.
Q = Hi-Temp Bolt - Threads toward Tip (1100°F) Specify size.

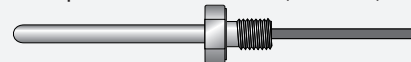

V = Bolt Transition - Threads toward Leads (500°F) Specify size.
W = Hi-Temp Bolt - Threads toward Leads (1100°F) Specify size.



R = Compression Fitting - Threads toward Leads (500°F) Specify size.
S = Hi-Temp Compression Fitting - Threads toward Leads (1100°F)



T = Compression - Double Ended (500°F) Specify size.
U = Hi-Temp Compression - Double Ended (1100°F) Specify size.



N = No Transition - Lead wires welded or brazed to sensor
Z = Special

Style O – Base Metal Assembly

GIC Thermodynamics offers Style O - Industrial Base Metal Thermocouples in bare wire and ceramic insulated elements. They are available in straight and angled configurations for a wide variety of applications. Base Metal T/C's are also available in complete protection tube assemblies see Style T and Style P

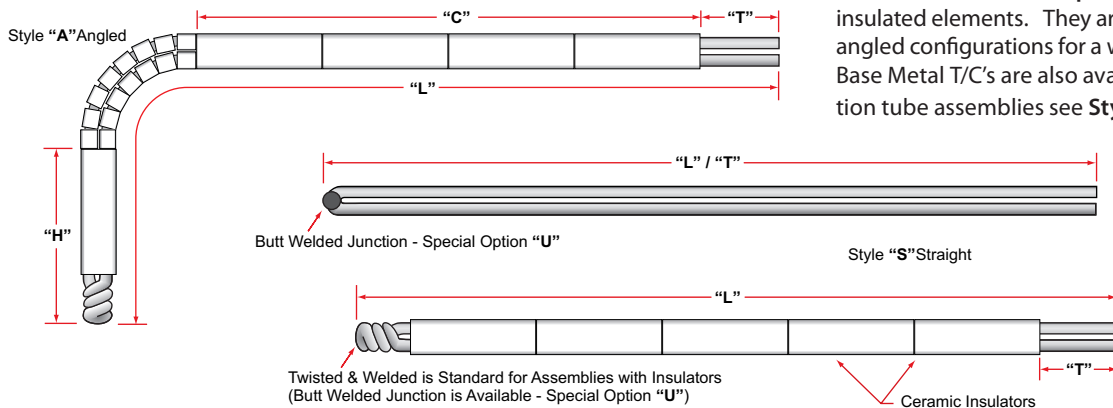

1. Style

S = Straight
A = Angled

2. Calibration (See page 12 for other Cals)

J = Type J (1400°F) K = Type K (2300°F)

3. Junction* (See Diagram BM-J)

G = Grounded Tip (Bare)
U = Ungrounded Tip (Covered)

*GIC Standard Junction is Twisted & Welded.
Choose Butt Welded under Special Options

4. Element Type

A = Single B = Duplex

5. Overall Length "L" (Example 12.5 = 12-1/2 inches)

Specify Length in Inches

6. Insulator Type (See Diagram BM-IS)

N = None
R = Round
V = Oval

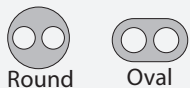

7. Conductor Gauge

E = 8 AWG P = 14 AWG

Other gauges available consult factory

8. Bare Lead Length "T" (Same as "L" if no insulators are selected)

Specify Length in Inches

ANGLED STYLE ONLY

11. Cold Length "C" (Angled Only)
Specify Length in Inches

10. Hot Length "H" (Angled Only)
Specify Length in Inches

9. Special Options (Choose all that apply)

N = None
A = Special Limits of Error
U = Butt Welded Junction
Z = Other (Consult Factory)

Diagram BM-J

Junctions

Twisted & Welded (Std)



Butt Welded (Option "U")

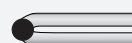

Diagram BM-IS

Insulation Construction	Insulator Type Code	Wire Gauge	Insulator Dimensions	
			Single	Duplex
Bare Wire	-	Any	NA	NA
Round Insulator	R	14 Gauge	.250 OD	.320 OD
Oval Insulator	V	8 Gauge	.465 OD	NA
Round Insulator	R	14 Gauge	.313 x .188	.436 x .436
Oval Insulator	V	8 Gauge	.490 x .286	.572 x .572

For more information on base metal sensors,
please visit:

www.GICSensors.com

Style B – Basic MgO Assembly

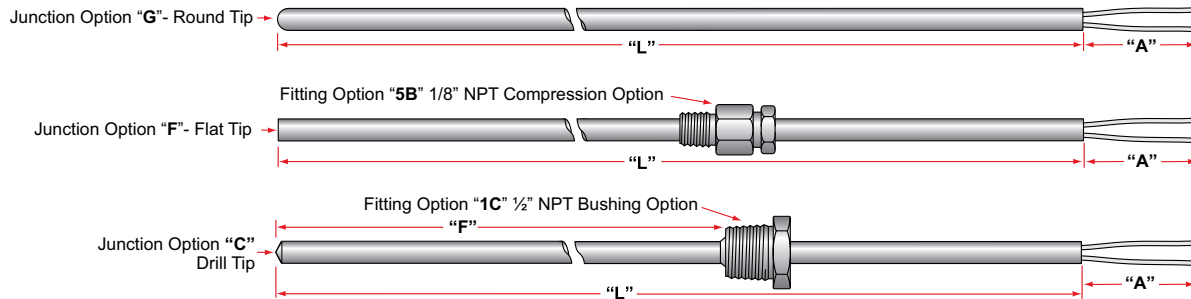

1. Calibration (See page 12 for other Cals)

J = Type J (1400°F) T = Type T (700°F)
 K = Type K (2300°F) E = Type E (1600°F)

2. Junction (See Diagram TS-TC)

	Grounded	Ungrounded
Round Tip	G (Std)	U
Flat Tip	F	B
118° Drill Tip	D	C
Needle Tip	P	M
Reduced Tip	R	Q
Exposed Tip	-	E

3. Element Type

A = Single B = Duplex* C = Triplex*

* Common Ungrounded is Standard for Ungrounded Junctions
 For Separated Ungrounded choose "O" under Special Options

4. Sheath Material (See page 13 for other Materials)

4 = 304SS (1650°F)(Std) 0 = 310SS (2100°F)
 6 = 316SS (1650°F) I = INCONEL (2150°F)

5. Sheath Diameter (Metric sizes also available)

B = .020 D = .040 H = .188* M = .375
 C = .032 F = .063* I = .250* P = .500
 G = .125* Q = .313 Z = Other * Quick delivery

6. Sheath Length "L" (Example 12.5 = 12-1/2 inches)

0.25 - 999 inches Z = greater than 999 inches (Consult Factory)

7. Strip Length "A" (1"std - 6" max in whole inches)

8. Fittings (See page 15 for more info and other fittings)(Metric sizes also available)

N = None (Std) FB = Fixed Bayonet Fitting (.188 and .250 Dia only) Z = Other

NPT Fittings	1/8" NPT	1/4" NPT	1/2" NPT	3/4" NPT	SPECIAL
Fixed Bushing (Stainless)	1A	1B	1C	1D	1Z
Fixed Hex Nipple (Steel)	2A	2B	2C	2D	2Z
Fixed Hex Nipple (Stainless)	3A	3B	3C	3D	3Z
Spring Loaded Hex Nipple (Stainless)	-	-	4C	-	4Z
Compression (Brass) one time adj.	5A	5B	5C	-	5Z
Compression (Stainless) one time adj.	6A	6B	6C	-	6Z
Compression (Stainless) re-adjustable*	7A	7B	7C	-	7Z

*Teflon® gland standard (400°F) for other gland options such as Lava (1200°F) see page 15

12. Bend Location "C" (inches from tip) N = No Bend(Std)

(See "Diagram BEND" on Page 19 for more on Bend Location)

11. Bend Angle

N = None(Std)
 G = 45 Degree Bend
 S = 90 Degree Bend
 Z = Other

10. Special Options (Choose all that apply)

N = None
 A = Special Limits of Error
 O = Separate Ungrounded Junctions
R = Faster Response Construction
 Y = Certificate of Conformance
 W = Weld Pad (See Page 19)
 X = X-Ray Junction
 Z = Other (Consult Factory)

9. Fitting Location "F" (inches from tip) N = No Location (Std)

Diagram TS-TC (see page 14)

Junction Tip Style	Grounded Junction	Ungrounded Junction
Round Tip	G(Std)	U
Flat Tip	F	B
118° Drill Tip	D	C
Needle Tip	P	M
Reduced Tips	R	Q
Exposed Tip	-	E

Mineral Insulated (MgO) Thermocouples

Style D – Quick Disconnect Assembly

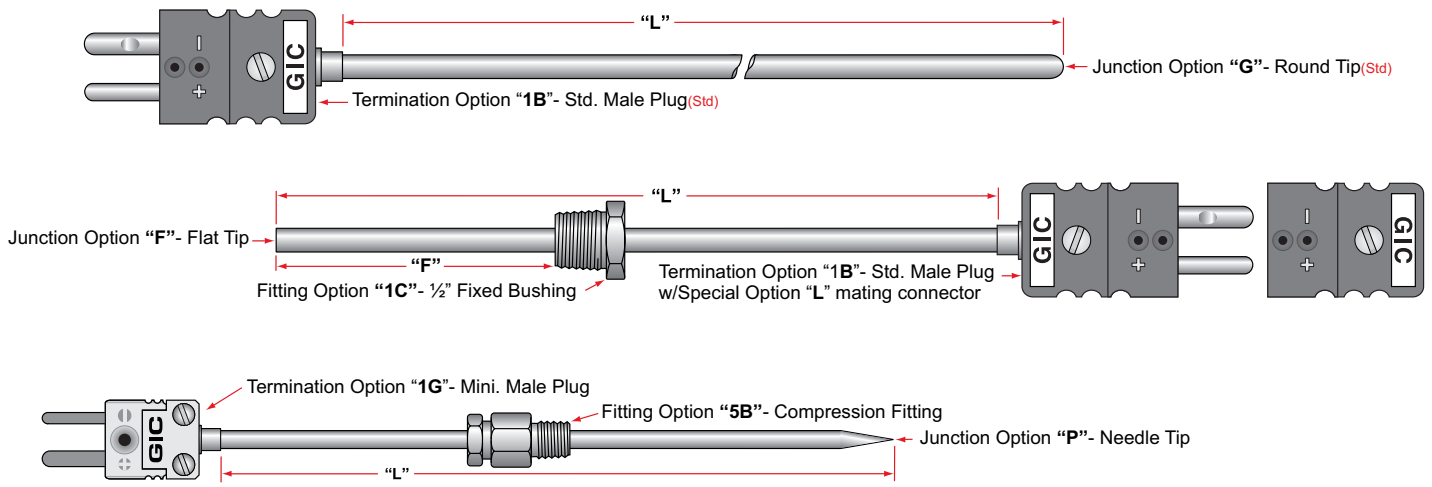

1. Calibration (See page 12 for other calcs)
 J = Type J (1400°F) T = Type T (700°F)
 K = Type K (2300°F) E = Type E (1600°F)

2. Junction (See Diagram TS-TC)

	Grounded	Ungrounded
Round Tip	G (Std)	U
Flat Tip	F	B
118° Drill Tip	D	C
Needle Tip	P	M
Reduced Tip	R	Q
Exposed Tip	-	E

3. Element Type
 A = Single B = Duplex*
 * Common Ungrounded is Standard for Ungrounded Junctions
 For Separated Ungrounded choose "O" under Special Options

4. Sheath Operating Temperature
 A = -200°C to 260°C (500°F) D = 0°C to 900°C (1650°F)
 B = -200°C to 400°C (750°F) E = 0°C to 1150°C (2100°F)
 C = -200°C to 600°C (1200°F) Z = Other

5. Sheath Material (See page 13 for other Materials)
 4 = 304SS (1650°F)(Std) 0 = 310SS (2100°F)
 6 = 316SS (1650°F) I = INCONEL (2150°F)

6. Sheath Diameter (Metric sizes also available)
 A = .010 D = .040 H = .188* M = .375
 B = .020 F = .063* I = .250* P = .500
 C = .032 G = .125 Q = .313 Z = Other * Quick delivery

7. Sheath Length "L" (Example 12.5 = 12 1/2 inches)
 0.25 - 999 inches Z = greater than 999 inches (Consult Factory)

Attention OEMs: GIC uses the highest quality connectors on our Style D assemblies. But if you have a specific brand that you would rather we use just let us know. GIC builds assemblies with most of the major brands of connectors.

www.GICThermodynamics.com

Diagram BEND

INFORMATION FOR ORDERING A SENSOR WITH A BEND

Factory Bend Standards:

For 45° bends "C" is measured from the tip to the start of the bend.

For 90° bends "C" is measured from the tip to the center-line of the sheath.

For Bends other than 45° or 90° consult factory.

Chart - RD

SHEATH DIAMETER	BEND RADIUS
1/8" (.125)	3/8" Radius
3/16" (.188)	7/16" Radius
1/4" (.250)	9/16" Radius
3/8" (.375)	15/16" Radius
1/2" (.500)	1-1/2" Radius

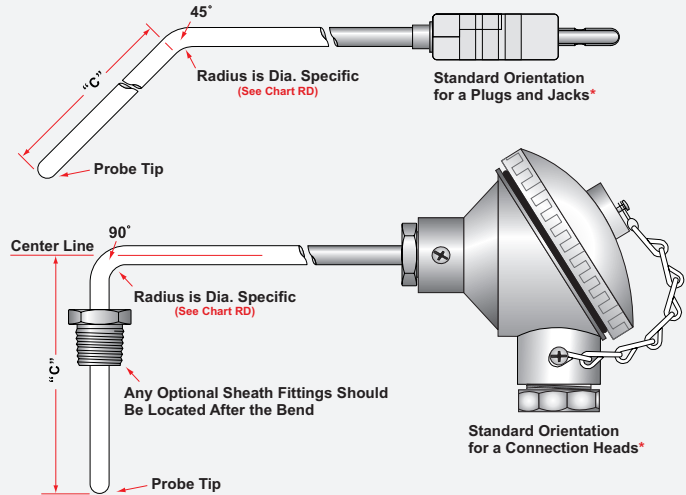

Notes:

For RTD's the minimum "C" dimension is the length of the element plus 1/2".

*For Orientations of terminations other than standard consult factory.

13. Bend Location "C" (Inches from tip, see "Diagram BEND") N = No Bend (Std)

12. Bend Angle

N = None(Std) G = 45 Degree Bend S = 90 Degree Bend Z = Other

11. Special Options

N = None
A = Special Limits of Error
L = Mating Connector
P = Electro-etching
T = Coated Probe

O = Separate Ungrounded Junctions
R = Faster Response Construction
Y = Certificate of Conformance
X = X-Ray Junction
Z = Other (Consult Factory)

10. Fitting Location "F" (Inches from tip) N = No Fitting Location (Std)

9. Fittings (See page 15 for more info and other fittings) (Metric fittings also available)

N = None (Std) FB = Fixed Bayonet Fitting (.188 and .250 Dia only) Z = Special

NPT Fittings	1/8" NPT	1/4" NPT	1/2" NPT	3/4" NPT	SPECIAL
Fixed Bushing (Stainless)	1A	1B	1C	1D	1Z
Fixed Hex Nipple (Steel)	2A	2B	2C	2D	2Z
Fixed Hex Nipple (Stainless)	3A	3B	3C	3D	3Z
Spring Loaded Hex Nipple (Stainless)	-	-	4C	-	4Z
Compression (Brass) one time adj.	5A	5B	5C	-	5Z
Compression (Stainless) one time adj.	6A	6B	6C	-	6Z
Compression (Stainless) re-adjustable*	7A	7B	7C	-	7Z

*Teflon® gland standard (400°F) for other gland options such as Lava (1200°F) see page 15

8. Terminations

PLUGS & JACKS	Std Temp (425°F)	Hi-Temp (660°F)	Ceramic (1200°F)
Std Male Plug	1B	2B	3B
Std Female Jack	1D	2D	3D
Mini Male Plug	1G	2G	3G
Mini Female Jack	1L	2L	3L

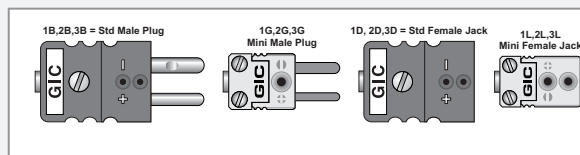
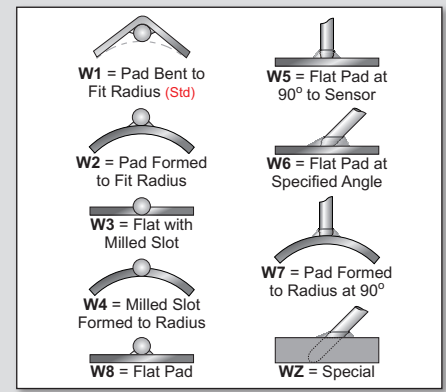

Diagram WP

Weld Pads Styles

Weld Pads are designed to facilitate welding of thermocouples and RTD's to pipes, tubes and other surfaces in the field. The standard size is a 1" by 1-1/4" by 0.090" 304 stainless steel plate welded to the sensor junction. To order put a "W" in the Special Options field of the Sensor Part Number. If multiple pads are required put a "W" in the part number for each pad required. (Style, Pad size, Material, Radius is required at time of order.)



Mineral Insulated (MgO) Thermocouples

Style F – Transition Assembly

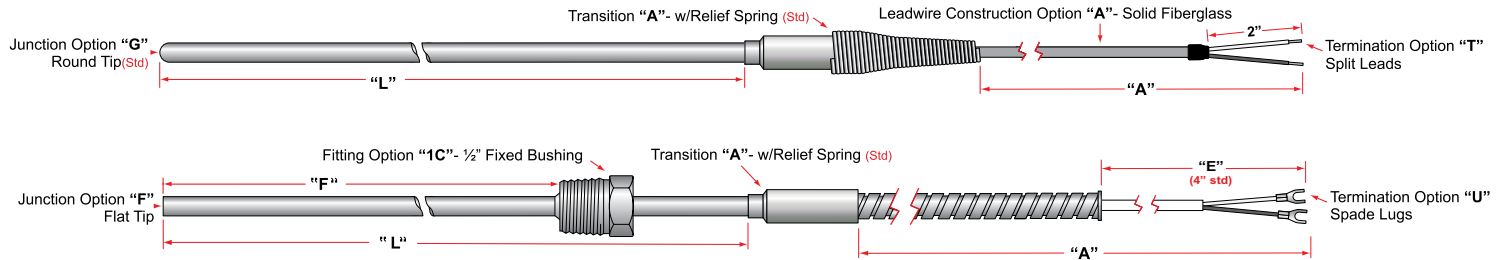

1. Transition (See page 15 for more transitions)
 A = Standard Transition w/Relief Spring (500°F) (Std)
 B = Standard Transition (500°F)
 C = Hi-Temp Transition w/Relief Spring (1100°F)
 D = Hi-Temp Transition (1100°F)

2. Calibration (See page 12 for other Cals)
 J = Type J (1400°F) T = Type T (700°F)
 K = Type K (2300°F) E = Type E (1600°F)

3. Junction (See Diagram TS-TC)

	Grounded	Ungrounded
Round Tip	G (Std)	U
Flat Tip	F	B
118° Drill Tip	D	C
Needle Tip	P	M
Reduced Tip	R	Q
Exposed Tip	-	E

4. Element Type
 A = Single B = Duplex* C = Triplex*
* Common Ungrounded is Standard for Ungrounded Junctions
 For Separated Ungrounded choose "O" under Special Options

5. Sheath Operating Temperature
 A = -200°C to 260°C (500°F) D = 0°C to 900°C (1650°F)
 B = -200°C to 400°C (750°F) E = 0°C to 1150°C (2100°F)
 C = -200°C to 600°C (1200°F) Z = Other

6. Sheath Material (See page 13 for other Materials)
 4 = 304SS (1650°F) (Std) 0 = 310SS (2100°F)
 6 = 316SS (1650°F) I = INCONEL (2150°F)

7. Sheath Diameter (Metric sizes also available)
 F = .063* G = .125* H = .188* I = .250* P = .500
 Q = .313 M = .375 Z = Other *Quick delivery
For smaller diameters see "Style FM - Miniature Transition Assemblies"

8. Sheath Length "L" (Example 12.5 = 12-1/2 inches)
 0.25 - 999 inches Z = greater than 999 inches (Consult Factory)

Diagram TS-TC (see page 14)

Junction Tip Style	Grounded Junction	Ungrounded Junction
Round Tip	G (Std)	U
Flat Tip	F	B
118° Drill Tip	D	C
Needle Tip	P	M
Reduced Tips	R	Q
Exposed Tip	-	E

NEED SAME DAY DELIVERY????
 GIC stocks the style F thermocouple in multiple diameters (.125, .188, .250) plus a variety of probe lengths, leadwire lengths and insulations.
 (See "Stock Sensors" - page 4)

The **Style F - Transition Assembly** is the most universal of all Thermocouple assemblies. It can be adapted to most applications where temperature measurement is required. It is available in a variety of lengths, sheath materials, leadwire insulations & terminations. It is a great choice for High Vibration and Field Bendable constructions.

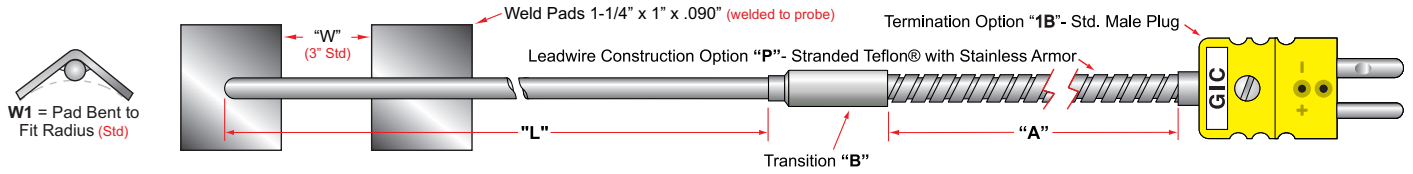

17. Bend Location "C" (Inches from tip, see "Diagram BEND" page 19) N = No Bend (Std)

16. Bend Angle
 N = None(Std) G = 45 Degree Bend S = 90 Degree Bend Z = Other

15. Special Options

N = None	L = Mating Connector	O = Separate Ungrounded Junctions
A = Special Limits of Error	P = Electro-etching	Q = Individual Leadwires (3/8" Strip Std)
G = Shielded Leadwire	T = Coated Probe	Y = Certificate of Conformance
I = SS ID Tag	W = Weld Pad (See Page 19)	R = Faster Response Construction
H = High Vibration	X = X-Ray Junction	3 = Test at Process Temperature
J = Coated Armor	7 = Rigid Tube Construction	Z = Special (Consult Factory)

14. Fitting Location "F" (Inches from tip) N = No Fitting Location (Std)

13. Fittings (See page 15 for more info and other fittings) (Metric fittings also available)

NPT Fittings	1/8" NPT	1/4" NPT	1/2" NPT	3/4" NPT	SPECIAL
Fixed Bushing (Stainless)	1A	1B	1C	1D	1Z
Fixed Hex Nipple (Steel)	2A	2B	2C	2D	2Z
Fixed Hex Nipple (Stainless)	3A	3B	3C	3D	3Z
Spring Loaded Hex Nipple (Stainless)	-	-	4C	-	4Z
Compression (Brass) one time adj.	5A	5B	5C	-	5Z
Compression (Stainless) one time adj.	6A	6B	6C	-	6Z
Compression (Stainless) re-adjustable*	7A	7B	7C	-	7Z

*Teflon® gland standard (400°F) for other gland options such as Lava (1200°F) see page 15

12. Leadwire Terminations: (See Diagram LT-TC)

	PLUGS & JACKS							
	Single & Duplex Only		Std Temp (425°F)		Hi Temp (660°F)		Ceramic (1200°F)	
	w/ clamp	w/o clamp	w/ clamp	w/o clamp	w/ clamp	w/o clamp	w/ clamp	w/o clamp
Std Male Plug	1A	1B	2A	2B	3A	3B		
Std Female Jack	1C	1D	2C	2D	3C	3D		
Mini Male Plug	1F	1G	2F	2G	3F	3G		
Mini Female Jack	1H	1L	2H	2L	3H	3L		

Diagram LT-TC

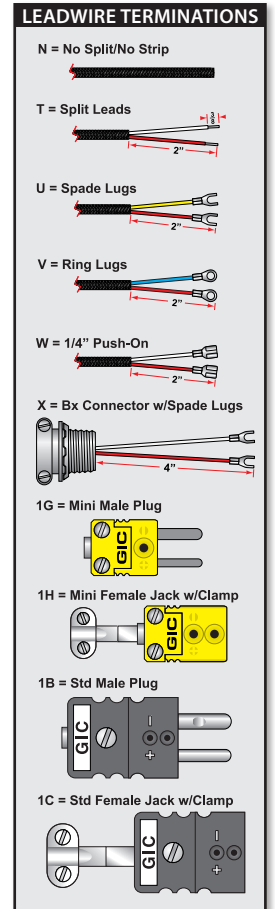

11. Leadwire Length "A" (Example 12.5 = 12-1/2 inches)

10. Leadwire Gauge
 A = 26 gauge B = 24 gauge C = 20 gauge

	Z = Special					
	(solid wire)			(stranded wire)		
	Standard	Overbraided	Armor	Standard	Overbraided	Armor
Fiberglass (900°F)	A (Std)	F	L	C	H	O
Teflon® (400°F)	B	G	W	D	I	P
Kapton® (700°F)	E	J	K	Q	R	S

For a larger selection of Transitions styles see page 15.

For more information on Transition Styles go to www.GICThermodynamics.com

Mineral Insulated (MgO) Thermocouples

Style H – Connection Head Assembly

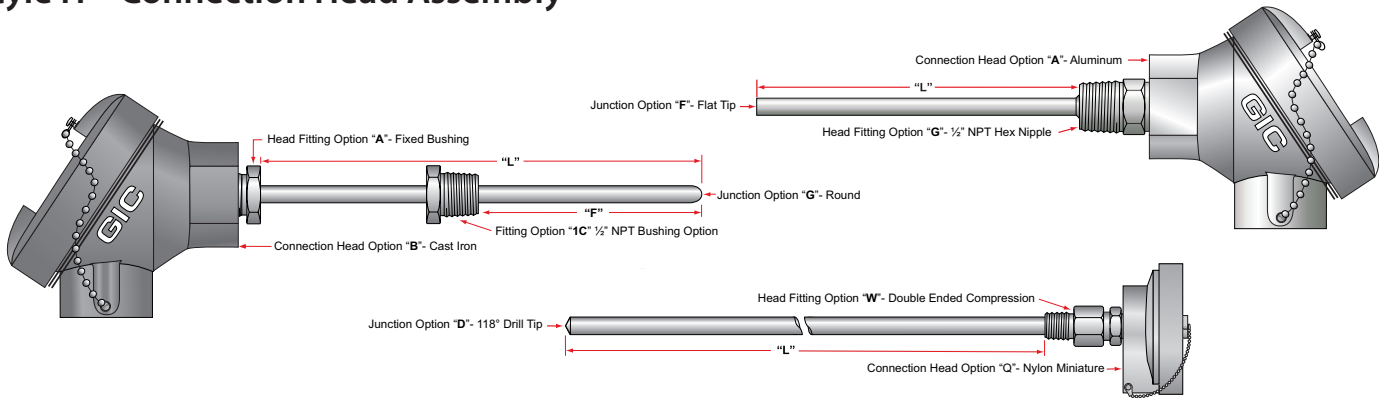

- 1. Connection Head**
- | | |
|----------------------|---|
| A = Aluminum | G = 316 Stainless Steel |
| B = Cast Iron | L = Oversized Aluminum |
| C = Explosion Proof* | O = Open - Ceramic Block |
| D = Poly Black | Q = Nylon Miniature |
| E = FDA Poly - Latch | V = Dan |
| F = Nylon | M = Alum. Miniature |
| R = Canister | * See page 34 for Explosion Proof head Info |

- 2. Calibration** (See page 12 for other Cals)
- J = Type J (1400°F) T = Type T (700°F)
 K = Type K (2300°F) E = Type E (1600°F)

3. Junction (See Diagram TS-TC)

	Grounded	Ungrounded
Round Tip	G (Std)	U
Flat Tip	F	B
118° Drill Tip	D	C
Needle Tip	P	M
Reduced Tip	R	Q
Exposed Tip	-	E

- 4. Element Type**
- A = Single B = Duplex* C = Triplex*
- * Common Ungrounded is Standard for Ungrounded Junctions
 For Separated Ungrounded choose "O" under Special Options

- 5. Sheath Operating Temperature**
- | | |
|------------------------------|----------------------------|
| A = -200°C to 260°C (500°F) | D = 0°C to 900°C (1650°F) |
| B = -200°C to 400°C (750°F) | E = 0°C to 1150°C (2100°F) |
| C = -200°C to 600°C (1200°F) | Z = Other |

- 6. Sheath Material** (See page 13 for other Materials)
- | | |
|-------------------------|----------------------|
| 4 = 304SS (1650°F)(Std) | 0 = 310SS (2100°F) |
| 6 = 316SS (1650°F) | I = INCONEL (2150°F) |

- 7. Sheath Diameter** (Metric sizes also available)
- | | | | | |
|-----------|-----------|----------|------------------|-----------|
| F = .063* | H = .188* | Q = .313 | P = .500 | Z = Other |
| G = .125* | I = .250* | M = .375 | * Quick delivery | |

- 8. Sheath Length "L"** (Example 12.5 = 12-1/2 inches)
- 0.25 - 999 inches Z = greater than 999 inches (Consult Factory)

For more Connection Head options and in-depth specifications go to:
www.GICThermodynamics.com

Style H Assemblies - GIC offers a variety of protection head assemblies designed to meet the most demanding applications. Quality units can be made to your exact specifications and/or are available from stock in select sheath diameters, lengths and calibrations. Connection heads protect wiring against dust, moisture and harsh environments. Style H Assemblies are available with a variety of optional, linearized head mounted transmitters. See page 36 for assemblies with Thermowells, and pages 34-35 for assemblies used with existing Thermowells and Protection Tubes.

CONNECTION HEAD OPTIONS

A = Aluminum **B = Iron Head** **C = Cast Aluminum EP**
S = 316 Stainless Steel EP **H = FDA Poly - Chain**
D = Black Poly - Chain **E = FDA Poly - Latch** **F = Nylon Head**

G = 316 Stainless **M = Alum. Miniature** **Q = Nylon Miniature**
L = Oversized Aluminum **V = Dan Head**

O = Open Ceramic Block **R = Canister**

For more Connection Head options go to www.GICthermodynamics.com

14. Bend Location "C" (Inches from tip, see "Diagram BEND" page 19) N = No Bend (Std)

13. Bend Angle (See Page 19 for more information)
 N = None(Std) G = 45 Degree Bend S = 90 Degree Bend Z = Other

12. Special Options

- | | |
|---|--------------------------------|
| N = None | P = Electro-etching |
| A = Special Limits of Error | S = Spring Loaded |
| D = Universal Transmitter* | T = Coated Probe |
| E = Economy Multi-input Transmitter* | Y = Certificate of Conformance |
| H = High Vibration | W = Weld Pad (See Page 19) |
| I = SS ID Tag | X = X-Ray Junction |
| O = Separate Ungrounded Junctions | Z = Special (Consult Factory) |
| R = Faster Response Construction | |
- * Not available on some head styles

Junction Tip Style	Grounded Junction	Ungrounded Junction
Round Tip	G(Std)	U
Flat Tip	F	B
118° Drill Tip	D	C
Needle Tip	P	M
Reduced Tips	R	Q
Exposed Tip	-	E

11. Fitting Location "F" (Inches from tip) N = No Fitting Location (Std)

10. Fittings (See page 15 for more info and other fittings) (Metric fittings also available)
 N = None (Std) FB = Fixed Bayonet Fitting (.188 and .250 Dia only) Z = Special

NPT Fittings	1/8" NPT	1/4" NPT	1/2" NPT	3/4" NPT	SPECIAL
Fixed Bushing (Stainless)	1A	1B	1C	1D	1Z
Compression (Brass) one time adj.	5A	5B	5C	-	5Z
Compression (Stainless) one time adj.	6A	6B	6C	-	6Z
Compression (Stainless) re-adjustable*	7A	7B	7C	-	7Z

*Teflon® gland standard (400°F) for other gland options such as Lava (1200°F) see page 15

Diagram HF

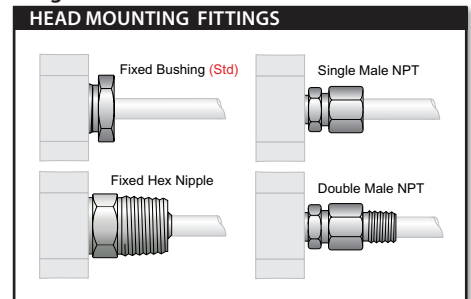

9. Head Mounting Fittings (See Diagram HF)

Hex Nipple Connection	1/4" NPT	1/2" NPT	3/4" NPT	Compression Fitting Connection	1/8" NPT	1/4" NPT	1/2" NPT
Fixed Hex Nipple (Steel)	F	G	H	Single Male NPT (Stainless)	-	-	S
Fixed Hex Nipple (Stainless)	I	J	K	Double Male NPT (Stainless)	W	X	Y

General Purpose Thermocouples

Style GP – Rigid Tube Assembly

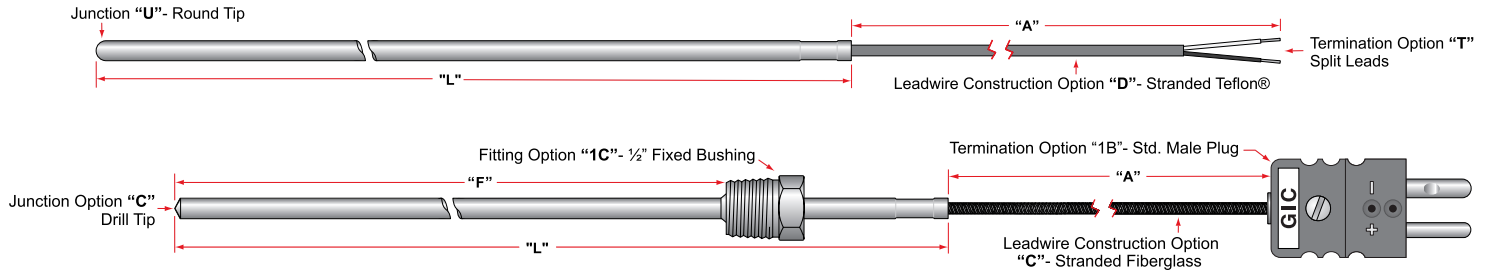

1. Calibration (See page 12 for other Cals)

J = Type J (1400°F) T = Type T (700°F)
 K = Type K (2300°F) E = Type E (1600°F)

2. Junction (See Diagram TS-TC)

	Grounded	Ungrounded
Round Tip	G (Std)	U
Flat Tip	F	B
118° Drill Tip	D	C
Needle Tip	P	M
Reduced Tip	R	Q
Exposed Tip	-	E

3. Element Type

A = Single B = Duplex* C = Triplex*

* Common Ungrounded is Standard for Ungrounded Junctions
 For Separated Ungrounded choose "O" under Special Options

4. Sheath Operating Temperature

A = -200°C to 260°C (500°F) D = 0°C to 900°C (1650°F)
 B = -200°C to 400°C (750°F) E = 0°C to 1150°C (2100°F)
 C = -200°C to 600°C (1200°F) Z = Other

5. Sheath Material (See page 13 for other Materials)

4 = 304SS (1650°F)(Std) I = INCONEL (2100°F)
 6 = 316SS (1650°F) C = Copper (1200°F)
 0 = 310SS (2100°F) E = Epoxy Glass (500°F)

6. Sheath Diameter (Metric sizes also available)

F = .063 H = .188* Q = .313 P = .500 Z = Other
 G = .125* I = .250* M = .375 * Quick delivery

7. Sheath Length "L" (Example 12.5 = 12-1/2 inches)

0.25 - 999 inches Z = greater than 999 inches (Consult Factory)

8. Leadwire Construction

Z = Other

	(solid wire)			(stranded wire)		
	Standard	Overbraid	Armor	Standard	Overbraid	Armor
Fiberglass (900°F)	A (Std)	F	L	C	H	O
Teflon® (400°F)	B	G	W	D	I	P
Kapton® (700°F)	E	J	K	Q	R	S

Style GP (General Purpose) is a Rigid Tube style thermocouple and is available in multiple styles for general applications to 900F. The GP is an economic alternative for applications where the advantages of the MgO design are not required. If the design you require is not a part of the stock program or not detailed on these pages, we will work with you to build an assembly to your exact specifications. Our sales engineers are here to assist.

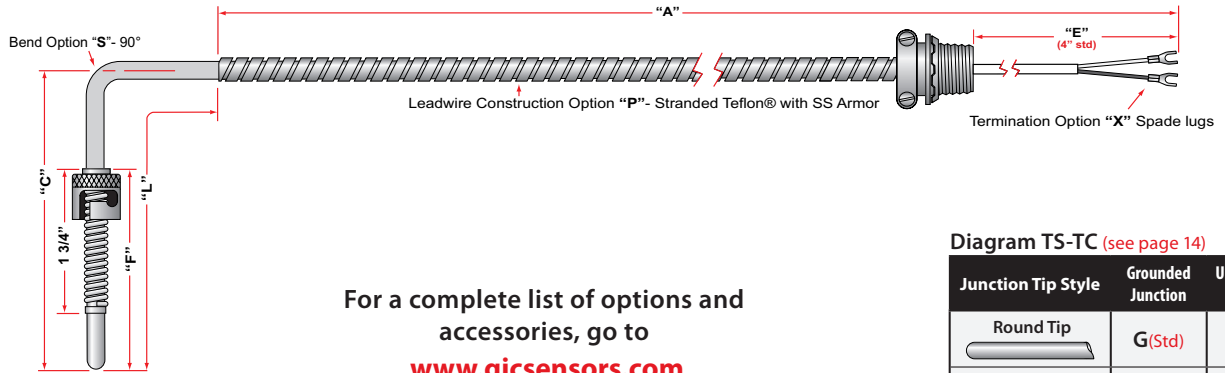

For a complete list of options and accessories, go to www.gicsensors.com

Diagram TS-TC (see page 14)

Junction Tip Style	Grounded Junction	Ungrounded Junction
Round Tip	G(Std)	U
Flat Tip	F	B
118° Drill Tip	D	C

16. Bend Location "C" (inches from tip, see "Diagram BEND" page 19) N = No Bend(Std)

15. Bend Angle (See Page 19 for more information)
 N = None(Std) G = 45 Degree Bend S = 90 Degree Bend Z = Other

14. Special Options

N = None	I = SS ID Tag	O = Separate Ungrounded Junctions
A = Special Limits of Error	L = Mating Connector	W = Weld Pad (See Page 19 for options)
G = Shielded leadwire	T = Coated Probe	Q = Individual Leadwires (3/8" Strip Std)
J = Coated Armor	P = Electro-etching	Z = Other (Consult Factory)

13. Fitting Location "F" (inches from tip) N = No Fitting Location (Std)

12. Fittings (See page 15 for more info and other fittings) (Metric fittings also available)

N = None (Std) FB = Fixed Bayonet Fitting (.188 and .250 Dia only) Z = Special

NPT Fittings	1/8" NPT	1/4" NPT	1/2" NPT	3/4" NPT	SPECIAL
Fixed Bushing (Stainless)	1A	1B	1C	1D	1Z
Fixed Hex Nipple (Steel)	2A	2B	2C	2D	2Z
Fixed Hex Nipple (Stainless)	3A	3B	3C	3D	3Z
Spring Loaded Hex Nipple (Stainless)	-	-	4C	-	4Z
Compression (Brass) one time adj.	5A	5B	5C	-	5Z
Compression (Stainless) one time adj.	6A	6B	6C	-	6Z
Compression (Stainless) re-adjustable*	7A	7B	7C	-	7Z

*Teflon® gland standard (400°F) for other gland options such as Lava (1200°F) see page 15

11. Leadwire Terminations: (See Diagram LT-TC)

N = No Split/ No Strip
 T = Split Leads (std = 2" split/3/8" strip)
 U = Spade Lugs (std = 2" split)
 V = Ring Lugs (std = 2" split)
 W = 1/4 Push-on (std = 2" split)
 X = Bx Connector w/ #8 lugs
 Z = Other

	PLUGS & JACKS		Std Temp (425°F)		Hi Temp (660°F)		Ceramic (1200°F)	
	w/ clamp	w/o clamp	w/ clamp	w/o clamp	w/ clamp	w/o clamp	w/ clamp	w/o clamp
Std Male Plug	1A	1B	2A	2B	3A	3B		
Std Female Jack	1C	1D	2C	2D	3C	3D		
Mini Male Plug	1F	1G	2F	2G	3F	3G		
Mini Female Jack	1H	1L	2H	2L	3H	3L		

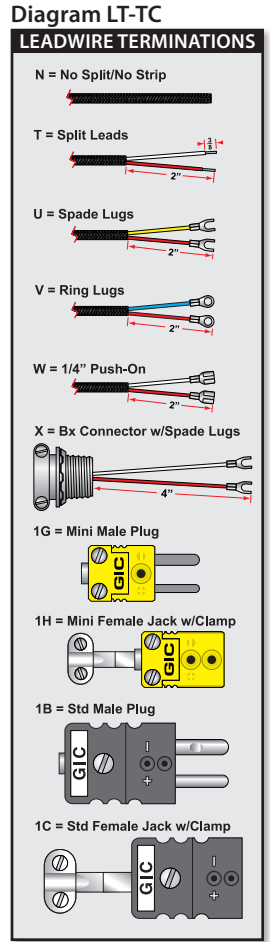

10. Leadwire Length "A" (Example 012= 12 inches)

9. Leadwire Gauge
 A = 26 gauge B = 24 gauge C = 20 gauge (Std) D = 30 gauge

General Purpose Thermocouples

Style IW – Insulated Wire Assembly

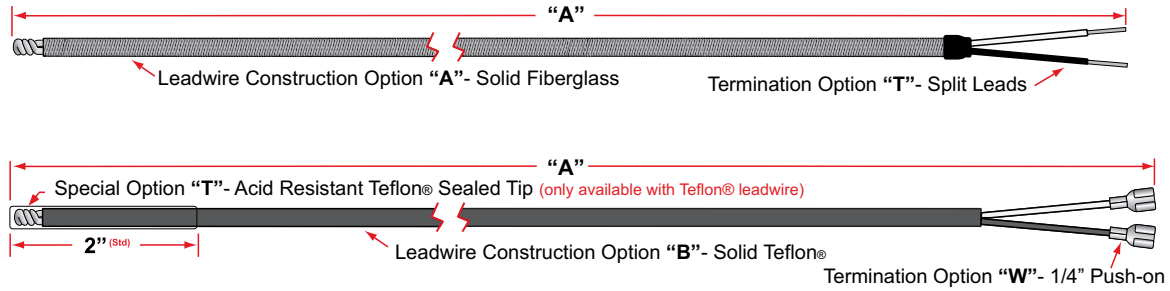

Style IW - Available in a variety of calibrations and insulations, the GIC Insulated Wire thermocouple provides an economical sensor for many general purpose applications. The optional Teflon® sheathed tip makes this a great sensor to use in corrosive applications. GIC stocks several configurations of Insulated Wire Assemblies (see page 8).



1. Calibration (See page 12 for other Cals)
 J = Type J (1400°F) T = Type T (700°F)
 K = Type K (2300°F) E = Type E (1600°F)

2. Leadwire Construction

Z = Other	(solid wire)		(stranded wire)	
	Standard	Overbraided	Standard	Overbraided
Fiberglass (900°F)*	A (Std)	F*	C	H*
Teflon® (500°F)	B	G*	D	I*
Kapton (700°F)	E	J*	Q	R*

*Not available with Acid Resistant Tip

3. Leadwire Gauge
 A = 26 gauge B = 24 gauge (Std) C = 20 gauge

4. Leadwire Length "A" (Example 12.5 = 12-1/2 inches)

5. Leadwire Terminations: (See Diagram LT-TC)

N = No Split/ No Strip	W = 1/4 Push-on (std = 2" split)
T = Split Leads (std = 2" split/3/8" strip)(Std)	X = Bx Connector w/ #8 lugs
U = Spade Lugs (std = 2" split)	Z = Special
V = Ring Lugs (std = 2" split)	

PLUGS & JACKS	Std Temp (425°F)		Hi Temp (660°F)		Ceramic (1200°F)	
	w/ clamp	w/o clamp	w/ clamp	w/o clamp	w/ clamp	w/o clamp
Std Male Plug	1A	1B	2A	2B	3A	3B
Std Female Jack	1C	1D	2C	2D	3C	3D
Mini Male Plug	1F	1G	2F	2G	3F	3G
Mini Female Jack	1H	1L	2H	2L	3H	3L

6. Special Options

N = None	U = Butt Welded Junction
A = Special Limits of Error	T = Acid Resistant Teflon® Sheathed Tip*
G = Shielded leadwire	Y = Certificate of Conformance
I = SS ID Tag	Z = Special (Consult Factory)
L = Mating Connector	

*Teflon® Jacket wire only

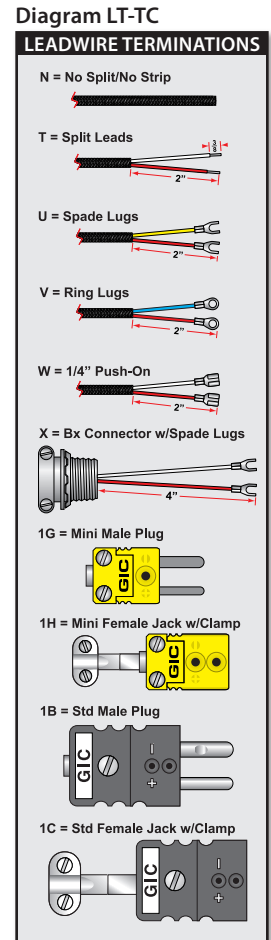

Style W – Washer Assembly

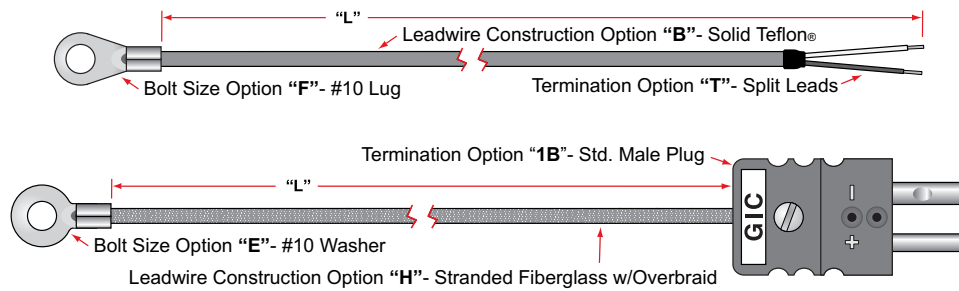

Style W - The Washer Assembly is a low cost surface mount temperature sensor. It can be easily mounted to a surface using screws or bolts. GIC can make this assembly to any length with a variety of insulations and attachments. It is carried in stock in a 20-gauge stranded fiberglass wire with stainless steel overbraid for abrasive applications up to 900F. High temperate nickel washers standard.

T W 1 - 2 3 N-N- 4 5 6 - 7 - 8

1. Washer/Lug

Bolt Size	Washer	Lug
#6	A	B
#8	C	D
#10	E	F
1/4"	G	H
5/16"	L	M
3/8"	N	P

Z = Other Size or Style

2. Calibration (See page 12 for other Cals)

J = Type J (1400°F) T = Type T (700°F)
 K = Type K (2300°F) E = Type E (1600°F)

3. Junction

G = Grounded U = Ungrounded

4. Leadwire Construction

	(solid wire)			(stranded wire)			Z=Other
	Standard	Overbraid	Armor	Standard	Overbraid	Armor	
Fiberglass (900°F)	A (Std)	F	L	C	H	O	
Teflon® (400°F)	B	G	W	D	I	P	
Kapton® (700°F)	E	J	K	Q	R	S	

5. Leadwire Gauge

A = 26 gauge B = 24 gauge (Std) C = 20 gauge

6. Leadwire Length "A" (Example 12.5 = 12-1/2 inches)

7. Leadwire Terminations:

N = No Split/ No Strip (Std)
T = Split Leads (std = 2" split/3/8" strip)
U = Spade Lugs (std = 2" split)
V = Ring Lugs (std = 2" split)
W = 1/4 Push-on (std = 2" split)
X = Bx Connector w/ #8 lugs
Z = Other

	PLUGS & JACKS		Std Temp (425°F)		Hi Temp (660°F)		Ceramic (1200°F)	
	w/ clamp	w/o clamp	w/ clamp	w/o clamp	w/ clamp	w/o clamp		
Std Male Plug	1A	1B	2A	2B	3A	3B		
Std Female Jack	1C	1D	2C	2D	3C	3D		
Mini Male Plug	1F	1G	2F	2G	3F	3G		
Mini Female Jack	1H	1L	2H	2L	3H	3L		

8. Special Options

N = None
 A = Special Limits
 G = Shielded leadwire
 L = Mating Connector
 Q = Individual Leadwires (3/8" Strip)
 Y = Certificate of Conformance
 Z = Other (Consult Factory)

Also available in an RTD version. Go to www.GICsensors.com

Style A – Embedment Bearing Assembly

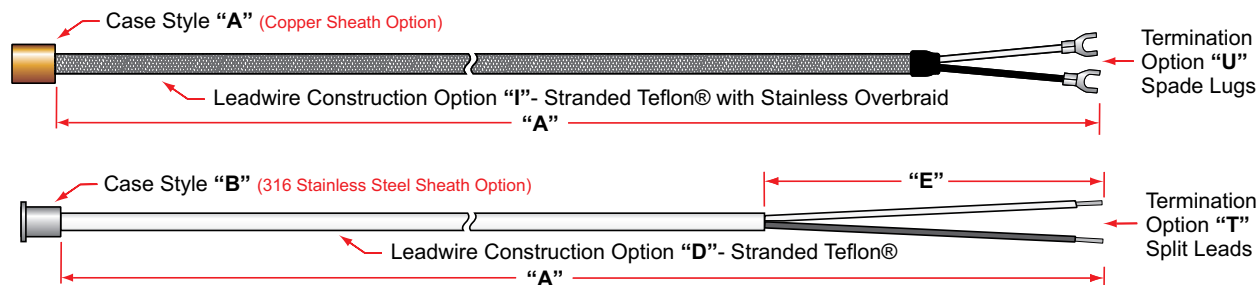

Style A - Embedment Assembly - Designed for monitoring bearing temperatures to provide advanced warning of lubrication oil breakdown before catastrophic bearing failure. Available in several case sizes, configurations and sheath materials. Standard operating range -32 to 266°F.

T A 1 - 2 3 4 A - 5 6 N - 7 8 9 - 10 11 - 12 - N

1. Case Style

A = Case A - 0.250" L, 0.275 Ø

B = Case B - 0.250" L, 0.188 Ø
0.250 Ø Flange

C = Case C - 0.300" L, 0.125 Ø

D = Case D - 0.250" L, 0.250 Ø

2. Calibration (See page 12 for other Cals)

J = Type J (1400°F) T = Type T (700°F)

K = Type K (2300°F) E = Type E (1600°F)

3. Junction **Grounded** **Ungrounded**

Flat Tip F B

4. Element Type

A = Single B = Duplex*

* Common Ungrounded is Standard for Ungrounded Junctions
For Separated Ungrounded choose "O" under Special Options

5. Sheath Material

4 = 304 6 = 316SS C = Copper B = Brass

K = Nickel Plated Copper U = Tin Plated Copper

6. Babbitt Tip

N = None B = Babbitt Tip (Styles A, B, and D only)

Reduces chance of overheating during installation

7. Leadwire Construction

Stranded wire	Standard	Overbraid	Individual Leads
Teflon® (400°F)	D (Std)	I	T

8. Leadwire Gauge (Case Style dependent)

A = 26 gauge (Std) B = 24 gauge D = 30 gauge

C = 20 gauge (Single Element Only)

9. Leadwire Length "A" (inches)

10. Leadwire Terminations:

N = No Split/ No Strip (Std)

T = Split Leads (std = 2" split/3/8" strip)

U = Spade Lugs (std = 2" split)

V = Ring Lugs (std = 2" split)

W = 1/4 Push-on (std = 2" split)

Z = Special

11. Split Length "E" (inches)

12. Special Options

N = None

A = Special Limits of Error

G = Shielded leadwire

O = Separate Ungrounded Junction

Q = Individual Leadwires (3/8" Strip)

Z = Special (Consult Factory)

Optional Pass-Through - Provides an oil tight seal to prevent the wicking of oil along the lead wires at the machine housing. To be used with standard compression fittings.



Style LN – Lockcap Armor Assembly

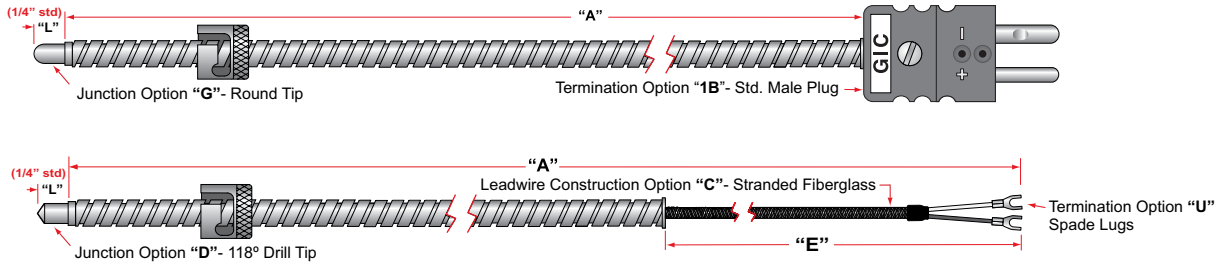

1. Calibration (See page 12 for other Cals)

J = Type J (1400°F) T = Type T (700°F)
 K = Type K (2300°F) E = Type E (1600°F)

2. Junction Grounded Ungrounded

Round Tip	G (Std)	U
Flat Tip	F	B
118° Drill Tip	D	C

3. Element Type

A = Single B = Duplex*
 * Common Ungrounded is Standard for Ungrounded Junctions
 For Separated Ungrounded choose "O" under Special Options

4. Sheath Material (See page 13 for other Materials)

4 = 304SS (1650°F) 6 = 316SS (1650°F)

5. Sheath Diameter

G = .125 H = .188(Std)

6. Sheath Length "L" (.25" Std)

0.25 - 99 inches Z = greater than 99 inches (Consult factory)

7. Leadwire Construction

	(solid wire)		(stranded wire)	
	Standard	Overbraid	Standard	Overbraid
Fiberglass (900°F)	A	F	C	H
Teflon® (400°F)	B	G	D	I
Kapton® (700°F)	E	J	Q	R

8. Leadwire Gauge

A = 26 gauge B = 24 gauge (Std)
 C = 20 gauge (.188 Dia.)

9. Armor Length "A" (Example 12.5 = 12-1/2)

10. Leadwire Terminations:

N = No Split/ No Strip
 T = Split Leads (std = 2" split/3/8" strip)
 U = Spade Lugs (std = 2" split)
 V = Ring Lugs (std = 2" split)
 W = 1/4 Push-on (std = 2" split)
 X = Bx Connector w/ #8 lugs
 Z = Other

PLUGS & JACKS

	Std Temp (425°F)		Hi Temp (660°F)		Ceramic (1200°F)	
	w/ clamp	w/o clamp	w/ clamp	w/o clamp	w/ clamp	w/o clamp
Std Male Plug	1A	1B	2A	2B	3A	3B
Std Female Jack	1C	1D	2C	2D	3C	3D
Mini Male Plug	1F	1G	2F	2G	3F	3G
Mini Female Jack	1H	1L	2H	2L	3H	3L

12. Special Options

N = None
 A = Special Limits of Error
 G = Shielded leadwire
 I = SS ID Tag
 L = Mating Connector
 Q = Individual Leadwires (3/8" Strip)
 Y = Certificate of Conformance
 Z = Special (Consult Factory)
Choose all that apply

Also available in an RTD version. Go to www.GICsensors.com

Need Bayonet Adaptors?

Several sizes are available in the stock accessories section see page 9



Style L – Lockcap Spring Assembly

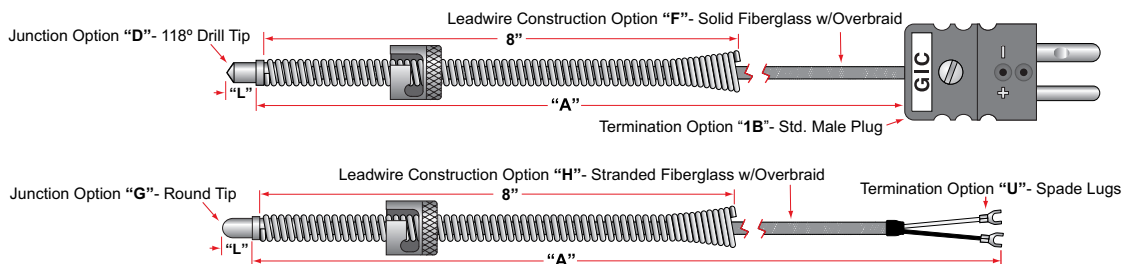

Need Bayonet Adaptors
Several sizes are available in the Accessories Section see page 9.

Style L - Lockcap Spring assembly is adjustable from 1/2" to 7" or 1/2" to 11" immersion depths depending on spring length chosen. It is used in combination with a bayonet adapter (see page 9) and is designed for quick installation and removal. The Style L can be used in a variety of applications.



1. Spring Length
A = 8" Spring
B = 12" Spring
C = Other

2. Calibration (See page 12 for other Cals)
J = Type J (1400°F) T = Type T (700°F)
K = Type K (2300°F) E = Type E (1600°F)

3. Junction	Grounded	Ungrounded
Round Tip	G (Std)	U
Flat Tip	F	B
118° Drill Tip	D	C

4. Element Type
A = Single B = Duplex*
*Common Ungrounded is Standard for Ungrounded Junctions For Separated Ungrounded choose "O" under Special Options

5. Sheath Material (See page 13 for other Materials)
4 = 304SS (1650°F) 6 = 316SS (1650°F) I = INCONEL (2150°F)

6. Sheath Diameter
G = .125 H = .188(Std)

7. Sheath Length "L"
.125 - 99.9 inches (Example .625 = 5/8 inch)

	(solid wire)		(stranded wire)	
	Standard	Overbraid	Standard	Overbraid
Fiberglass (900°F)	A	F	C	H
Teflon® (500°F)	B	G	D	I
Kapton (700°F)	E	J	Q	R

9. Leadwire Gauge
A = 26 gauge B = 24 gauge (Std) C = 20 gauge

10. Leadwire Length "A" (Example 12.5 = 12-1/2 inches)

12. Special Options (Choose all that apply)
N = None
A = Special Limits of Error
L = Mating Connector
K = Copper Tip (Fast Response)
O = Separate Ungrounded Junctions
Y = Certificate of Conformance
Z = Other (Consult Factory)

11. Leadwire Terminations:
N = No Split/ No Strip(Std) W = 1/4 Push-on (std = 2" split)
T = Split Leads (std = 2" split/3/8" strip) X = Bx Connector w/ #8 lugs
U = Spade Lugs (std = 2" split) Z = Other
V = Ring Lugs (std = 2" split)

PLUGS & JACKS	Std Temp (425°F)		Hi Temp (660°F)		Ceramic (1200°F)	
	w/ clamp	w/o clamp	w/ clamp	w/o clamp	w/ clamp	w/o clamp
Std Male Plug	1A	1B	2A	2B	3A	3B
Std Female Jack	1C	1D	2C	2D	3C	3D
Mini Male Plug	1F	1G	2F	2G	3F	3G
Mini Female Jack	1H	1L	2H	2L	3H	3L

Also available in an RTD version. Go to www.GICsensors.com

Style EX – Flexible TC Extension Harness

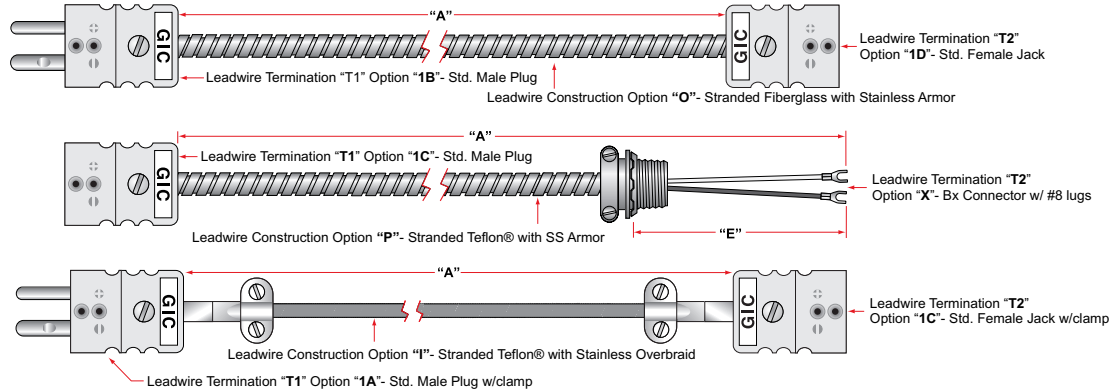

1. Configuration

A = Single (2 wire) (Std) B = Duplex (4 wire)

2. Calibration (See page 12 for other Cals)

J = Type J T = Type T K = Type K E = Type E

3. Leadwire Construction

	(solid wire)			(stranded wire)			Z = Other
	Standard	Overbraid	Armor	Standard	Overbraid	Armor	
Fiberglass (900°F)	A	F	L	C	H	O	
Teflon® (500°F)	B	G	W	D	I	P	
Kapton (700°F)	E	J	K	Q	R	S	
PVC (220°F)	U	-	Y	V	-	T	

4. Leadwire Gauge

A = 26 gauge B = 24 gauge C = 20 gauge (Std)

5. Leadwire Length "A" (Example 012= 12 inches)

6. Leadwire Length "E" (For leads beyond the armor) N = None (Std)

7. Leadwire Terminations "T1" (See Diagram LT-TC)

N = No Split/ No Strip (Std)
 T = Split Leads (std = 2" split/3/8" strip)
 U = Spade Lugs (std = 2" split)
 V = Ring Lugs (std = 2" split)
 W = 1/4 Push-on (std = 2" split)
 X = Bx Connector w/ #8 lugs
 Z = Other

PLUGS & JACKS	Std Temp (425°F)		Hi Temp (660°F)		Ceramic (1200°F)	
	w/ clamp	w/o clamp	w/ clamp	w/o clamp	w/ clamp	w/o clamp
Std Male Plug	1A	1B	2A	2B	3A	3B
Std Female Jack	1C	1D	2C	2D	3C	3D
Mini Male Plug	1F	1G	2F	2G	3F	3G
Mini Female Jack	1H	1L	2H	2L	3H	3L

8. Leadwire Terminations "T2" (See Diagram LT-TC)

N = No Split/ No Strip (Std)
 T = Split Leads (std = 2" split/3/8" strip)
 U = Spade Lugs (std = 2" split)
 V = Ring Lugs (std = 2" split)
 W = 1/4 Push-on (std = 2" split)
 X = Bx Connector w/ #8 lugs
 Z = Other

PLUGS & JACKS	Std Temp (425°F)		Hi Temp (660°F)		Ceramic (1200°F)	
	w/ clamp	w/o clamp	w/ clamp	w/o clamp	w/ clamp	w/o clamp
Std Male Plug	1A	1B	2A	2B	3A	3B
Std Female Jack	1C	1D	2C	2D	3C	3D
Mini Male Plug	1F	1G	2F	2G	3F	3G
Mini Female Jack	1H	1L	2H	2L	3H	3L

9. Special Options

N = None A = Special Limits of Error L = Mating Connector J = Coated Armor Z = Other (Consult Factory)

Diagram LT-TC

LEADWIRE TERMINATIONS

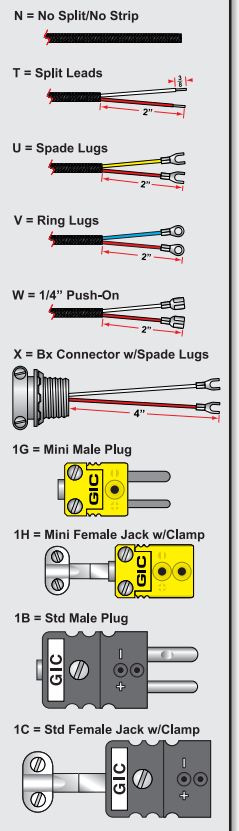

Also available in an RTD version. Go to www.GICsensors.com

Style M – Melt Bolt Thermocouple Assembly

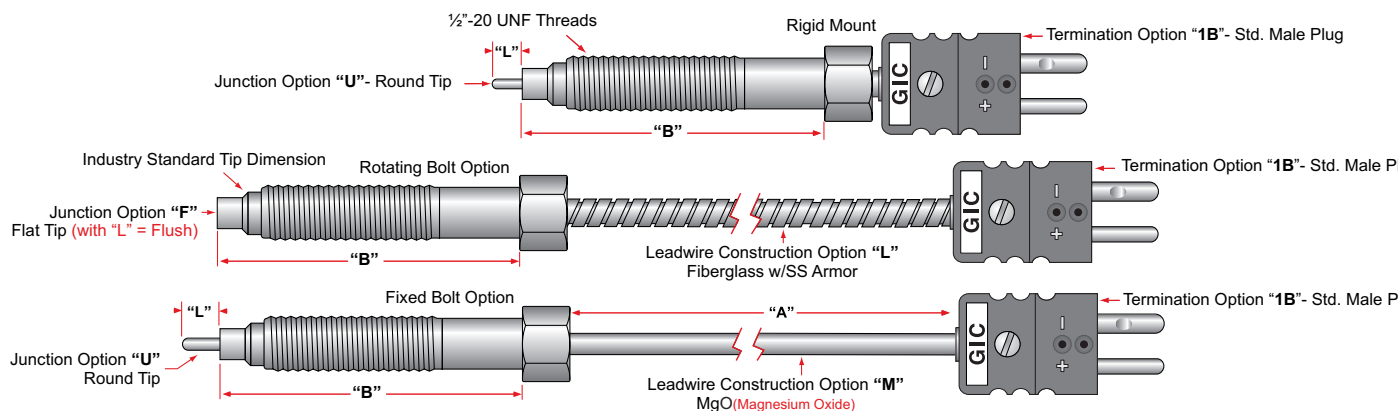

1. Bolt "B"

A = 3" Bolt B = 3" Rotating Bolt
 C = 4" Bolt D = 4" Rotating Bolt
 E = 6" Bolt F = 6" Rotating Bolt
 Z = Other (Consult Factory)

2. Calibration (See page 12 for other Cals)

J = Type J (1400°F) T = Type T (700°F)
 K = Type K (2300°F) E = Type E (1600°F)

3. Junction

	Grounded	Ungrounded
Round Tip	G (Std)	U
Flat Tip	F	B

4. Element Type

A = Single B = Duplex*

* Common Ungrounded is Standard for Ungrounded Junctions
 For Separated Ungrounded choose "O" under Special Options

5. Sheath Diameter

G = .125 (Std) H = .188 Z = Other

6. Sheath Length "L"

N = Flush A = 1/16" B = 1/8"
 C = 3/16" D = 1/4" E = 3/8"
 F = 1/2" G = 5/8" H = 3/4"
 L = 7/8" M = 1" Z = Other

7. Leadwire Construction

N = None (Choose for Rigid Mount)
 M = MgO (Magnesium Oxide Filled) (1600°F)
 L = Solid Fiberglass w/armor (900°F)(Std)
 O = Stranded Fiberglass w/armor (900°F)
 W = Solid Teflon® w/armor (900°F)
 P = Stranded Teflon® w/armor (900°F)
 Z = Other

8. Leadwire Gauge

B = 24 gauge
 C = 20 gauge
 M = MgO (Filled)
 Y = Rigid Tube
 Z = Other

9. Leadwire Length "A" (Example 12.5 = 12-1/2 inches)

Also available in an RTD version. Go to www.GICSensors.com

11. Special Options (Choose all that apply)

N = None
 I = SS ID Tag
 L = Mating Connector
 O = Separate Ungrounded Junctions
 Y = Certificate of Conformance
 Z = Special (Consult Factory)

10. Leadwire Terminations:

N = No Split/ No Strip
 T = Split Leads (std = 2" split/3/8" strip)(Std)
 U = Spade Lugs (std = 2" split)
 V = Ring Lugs (std = 2" split)
 W = 1/4 Push-on (std = 2" split)
 X = Bx Connector w/ #8 lugs
 Z = Special (Consult Factory)

PLUGS & JACKS	Std Temp (425°F)		Hi Temp (660°F)		
	Single & Duplex Only	w/ clamp	w/o clamp	w/ clamp	w/o clamp
Std Male Plug	1A	1B	2A	2B	
Std Female Jack	1C	1D	2C	2D	
Mini Male Plug	1F	1G	2F	2G	
Mini Female Jack	1H	1L	2H	2L	

For a larger selection of Special Purpose Assemblies go to: www.GICThermodynamics.com

Style N – Threaded Nozzle Thermocouple Assembly

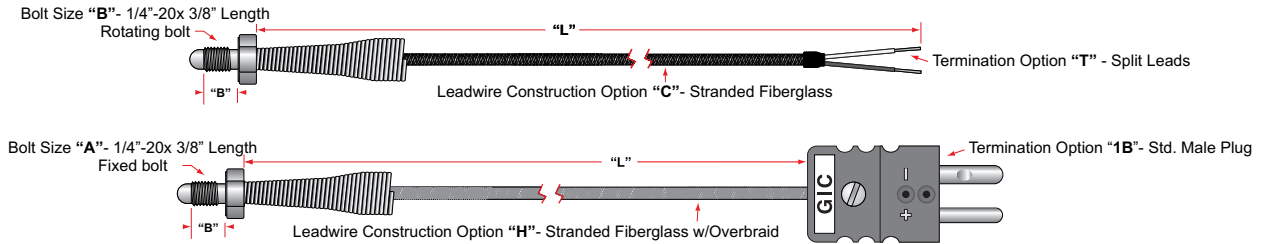

1. Bolt Size "B"

A = 1/4"-20 x 3/8" Fixed
 B = 1/4"-20 x 3/8" Rotating
 C = 1/4"-28 x 3/8" Fixed
 D = 1/4"-28 x 3/8" Rotating
 E = 8mm x 1.25 x 12 Fixed
 F = 8mm x 1.25 x 12 Rotating
 Z = Other Size

2. Calibration

J = Type J T = Type T Z = Other
 K = Type K E = Type E

3. Junction

	Grounded	Ungrounded
Round Tip	G (Std)	U
Flat Tip	F	B
118° Drill Tip	D	C

4. Bolt Material

4 = 304SS (1650°F) 6 = 316SS (1650°F) Z = Other

5. Leadwire Construction

Z=Other	(solid wire)		(stranded wire)	
	Standard	Overbraid	Standard	Overbraid
Fiberglass (900°F)	A (Std)	F	C	H
Teflon® (500°F)	B	G	D	I
Kapton (700°F)	E	J	Q	R

6. Leadwire Gauge

A = 26 gauge B = 24 gauge (Std) C = 20 gauge

7. Leadwire Length "A" (Example 12.5 = 12-1/2 inches)

8. Leadwire Terminations: (See Diagram LT-TC)

	PLUGS & JACKS					
	Single & Duplex Only					
	Std Temp (425°F)		Hi Temp (660°F)		Ceramic (1200°F)	
	w/ clamp	w/o clamp	w/ clamp	w/o clamp	w/ clamp	w/o clamp
Std Male Plug	1A	1B	2A	2B	3A	3B
Std Female Jack	1C	1D	2C	2D	3C	3D
Mini Male Plug	1F	1G	2F	2G	3F	3G
Mini Female Jack	1H	1L	2H	2L	3H	3L

Also available in an RTD version. Go to www.GICsensors.com

9. Special Options

N = None
 A = Special Limits of Error
 G = Shielded leadwire
 I = SS ID Tag
 L = Mating Connector
 Y = Certificate of Conformance
 Z = Other (Consult Factory)
 (Choose all that apply)

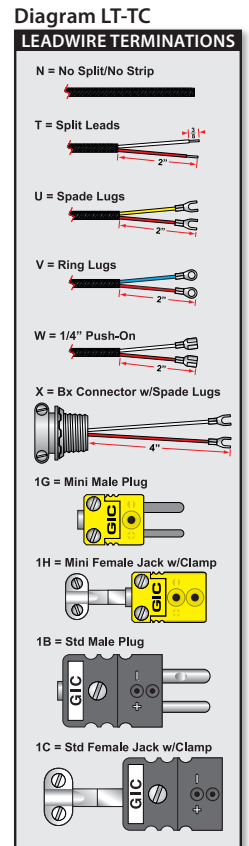

T/C's for Existing Thermowells

Style T – Connection Head Assembly For Wells and Protection Tubes (MgO Std)

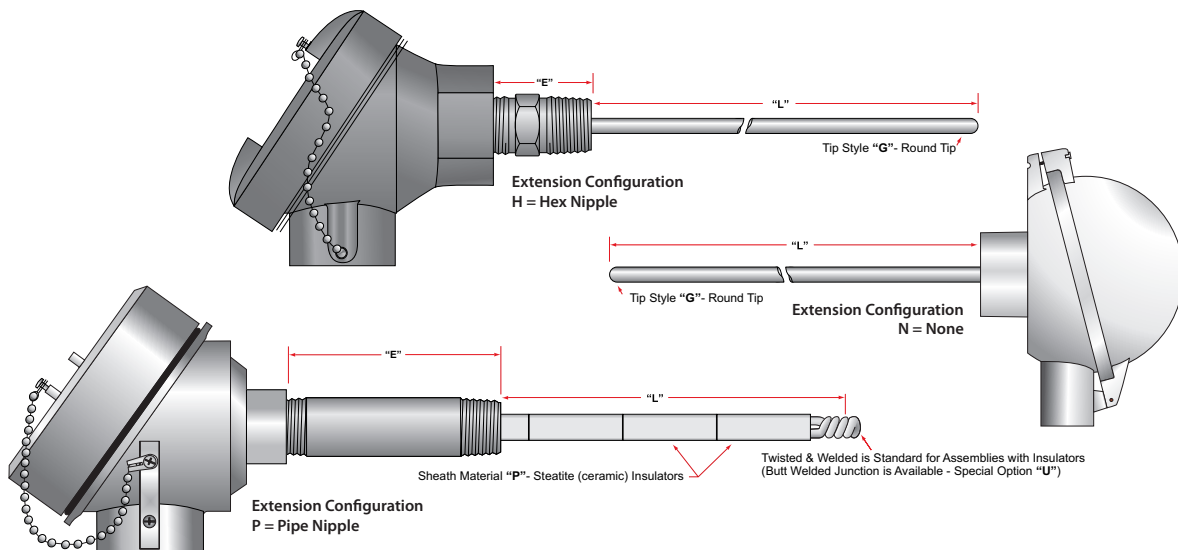

1. Connection Head

A = Aluminum G = 316 Stainless Steel
 B = Cast Iron S = 316SS Explosion Proof
 C = FMCUS Alum. EXP V = Dan
 D = Poly Black - Chain Y = APEX Aluminum EXP
 E = FDA Ploy - Latch (Consult Factory for Specialty Heads)

2. Calibration (See page 12 for other Cals)

J = Type J (1400°F) T = Type T (700°F)
 K = Type K (2300°F) E = Type E (1600°F)

3. Junction (See page 14)

	Grounded	Ungrounded
Round Tip	G (Std)	U
Flat Tip	F	B
118° Drill Tip	D	C

4. Element Type

A = Single B = Duplex* C = Triplex*

* Common Ungrounded is Standard for Ungrounded Junctions
 For Separated Ungrounded choose "O" under Special Options

5. Sheath Operating Temperature

A = -200°C to 260°C (500°F) D = 0°C to 900°C (1650°F)
 B = -200°C to 400°C (750°F) E = 0°C to 1150°C (2100°F)
 C = -200°C to 600°C (1200°F) Z = Other

6. Sheath Material (See page 13 for other Materials)

4 = 304SS (1650°F)(Std) 0 = 310SS (2100°F)
 6 = 316SS (1650°F) C = Copper (1000°F)
 I = INCONEL (2150°F)
 A = Alumina Insulator (3000°F)
 P = Steatite (Porcelain) Insulators (1830°F)
 L = Mullite Insulators (2640°F)

7. Sheath Diameter

I = .250 M = .375
 N = Insulators (Consult Factory if Specific Size Insulator is needed)

Change only for assemblies with insulators

	Round Insulator	Oval Insulator
8 Gauge	TR	TV
14 Gauge	SR	SV
20 Gauge	CR	CV

Connection Head Options - Explosion Proof

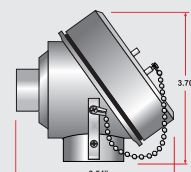

S = 316 Stainless Steel
 XDS-F: FMCUS Approved
 XDS-A: ATEX Approved
 C = Cast Aluminum
 XDA-F: FMCUS Approved
 Y = Cast Aluminum
 XDA-A: ATEX Approved

FMCUS (US & Canada) - meets all CSA standards & requirements Explosion Proof for Class I, Division 1, Groups A, B, C and D; and dust-ignition proof for Class II, III Division 1, Groups E, F and G, hazardous (classified) locations; indoor/ outdoor Aluminum: NEMA 4 5S316: NEMA 4X6

Style T – T/C'S for Thermowells and Protection Tubes

Style T - Thermocouple Thermowell Assemblies The MgO sensor are 1/4" and 3/8" OD and are meant to be used with existing .260" ID and .385" ID thermowells. The Insulated Wire sensors are meant to be used with existing 1/2" Protection tubes.

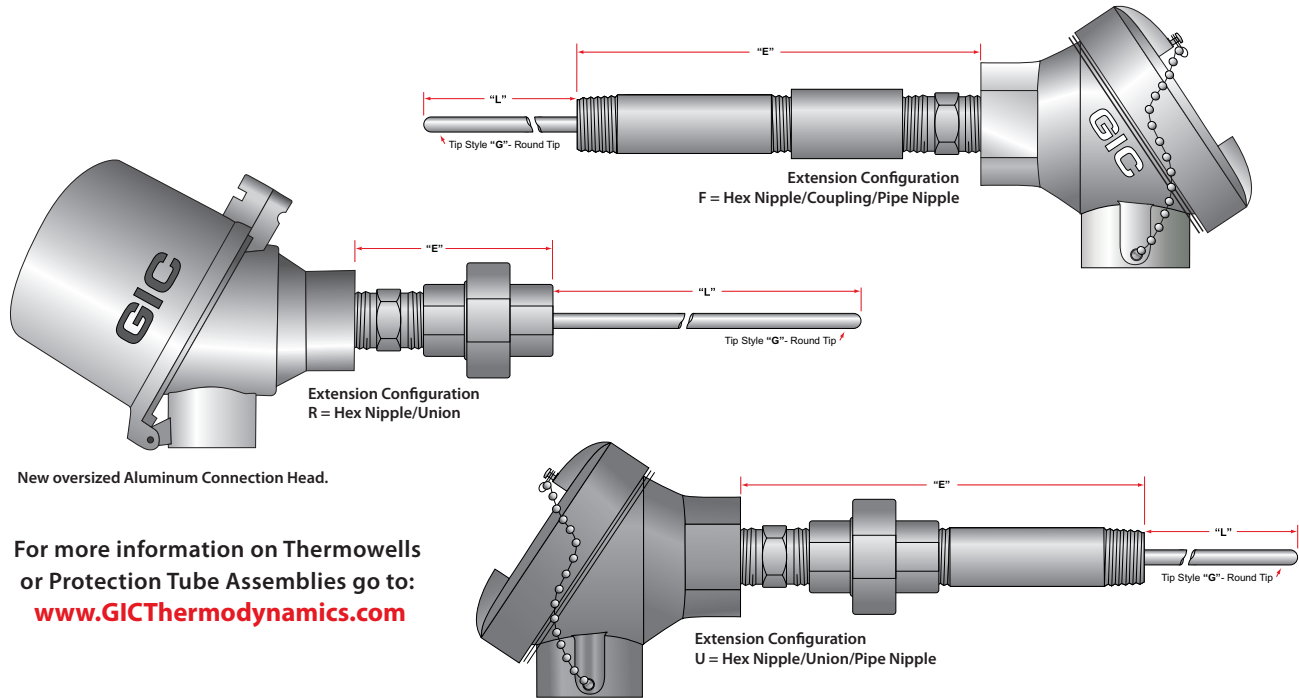

For more information on Thermowells or Protection Tube Assemblies go to: www.GICThermodynamics.com

Diagram PT-PIPE

Nominal Pipe Size	Outside Diameter	Sch 40 Wall Thickness	Sch 80 Wall Thickness
1/8"	0.405"	0.068"	0.095
1/4"	0.540"	0.088"	0.119
3/8"	0.675"	0.091"	0.129
1/2"	0.840"	0.109"	0.147
3/4"	1.050"	0.113"	0.154
1"	1.315"	0.133"	0.179
1-1/4"	1.660"	0.140"	0.191
1-1/2"	1.900"	0.145"	0.200
2"	2.375"	0.154"	0.218

12. Special Options

- N = None
- A = Special Limits of Error
- D = Universal Transmitter (See Page 57)
- E = Economy Multi-input Transmitter (See Page 57)
- I = SS ID Tag
- O = Separate Ungrounded Junctions
- P = Electro-etching
- S = Spring Loaded
- U = Butt Welded Junction
- Y = Certificate of Conformance
- X = X-Ray Junction
- 7 = Rigid Tube Construction
- Z = Other (Consult Factory)

11. Extension Length "E" (Example 12.5 = 12-1/2 Inches)

10. Extension Material

- S = Steel (Std)
- 4 = 304SS
- 6 = 316SS
- Z = Other

9. Extension configuration (starting at connection head)

- H = Hex Nipple
- R = Hex Nipple/Union
- U = Hex Nipple/Union/Pipe Nipple
- W = Hex Nipple/Union/Hex Nipple*
- P = Pipe Nipple
- S = Pipe Nipple/Union
- T = Pipe Nipple/Union/Hex Nipple
- V = Pipe Nipple/Union/Pipe Nipple*
- C = Hex Nipple/Coupling
- D = Pipe Nipple/Coupling
- F = Hex Nipple/Coupling/Pipe Nipple
- G = Pipe Nipple/Coupling/Hex Nipple

* (If this option is chosen then at least one of the pipe nipples lengths will have to be call out in the notes.)

8. Sheath Length "L" (Example 012= 12 inches)

- 00 - 99 inches
- Z = greater than 99 inches - Consult Factory

For more Connection Head options go to www.GICThermodynamics.com

Connection Head Options

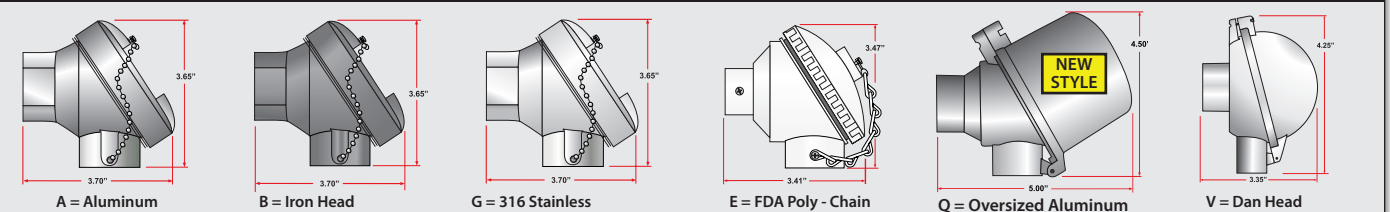

Thermocouple Thermowell Assemblies

Style U – Thermocouple Thermowell Assembly

Style U - Thermocouple Thermowell Assemblies are 1/4" and 3/8" OD sensors with .260" ID and .385" ID thermowells. To order build the sensor part number below then choose a thermowell from the pages 53-54 and put its part number after the sensor part number.

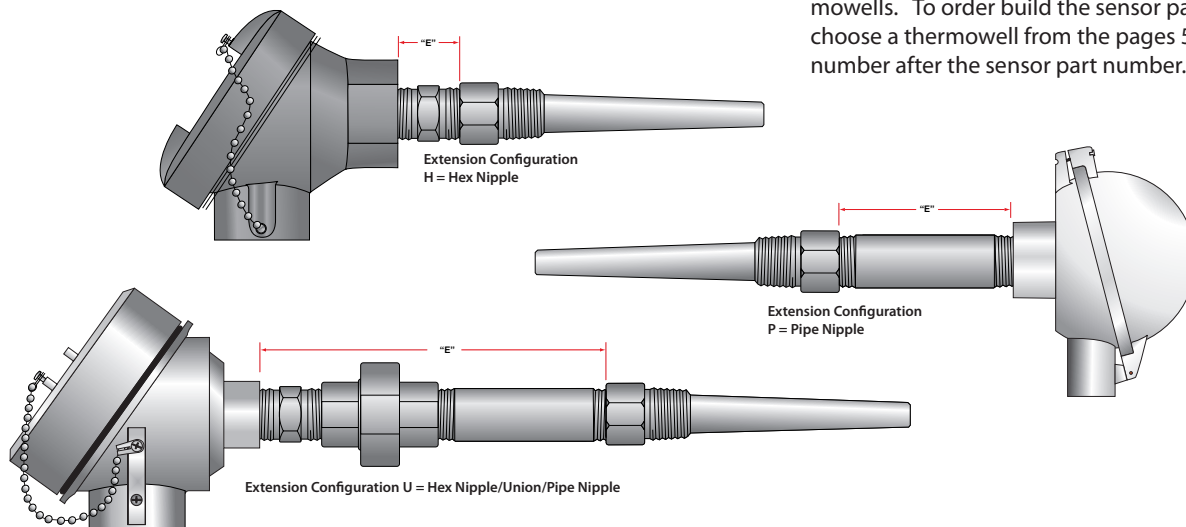

TU 1 - 2 3 4 5 - 6 7 -N- 8 9 10 - 11 - Thermowell Part Number 12

1. Connection Head

A = Aluminum G = 316 Stainless Steel
 B = Cast Iron S = 316SS Exp.
 C = FMCUS Alum. Exp. V = Dan
 D = Poly Black - Chain Y = APEX Alum. Exp.
 E = FDA Ploy - Latch (Consult Factory for Special Heads)

2. Calibration (See page 12 for other Cals)

J = Type J (1400°F) T = Type T (700°F)
 K = Type K (2300°F) E = Type E (1600°F)

3. Junction (See Diagram TS-TC)

	Grounded	Ungrounded
Round Tip	G (Std)	U
Flat Tip	F	B
118° Drill Tip	D	C

4. Element Type

A = Single B = Duplex* C = Triplex*
 * Common Ungrounded is Standard for Ungrounded Junctions
 For Separated Ungrounded choose "O" under Special Options

5. Sheath Operating Temperature

A = -200°C to 260°C (500°F) D = 0°C to 900°C (1650°F)
 B = -200°C to 400°C (750°F) E = 0°C to 1150°C (2100°F)
 C = -200°C to 600°C (1200°F) Z = Other

6. Sheath Material (See page 13 for other Materials)

4 = 304SS (1650°F)(Std) 0 = 310SS (2100°F)
 6 = 316SS (1650°F) C = Copper (1000°F)
 I = INCONEL (2150°F)
 A = Alumina Insulator (3000°F)
 P = Steatite (Porcelain) Insulators (1830°F)
 L = Mullite Insulators (2640°F)

7. Sheath Diameter

I = .250 M = .375 Consult factory for other diameters

8. Extension Configuration "E"

H = Hex Nipple
 P = Pipe Nipple
 U = Hex Nipple/Union/Pipe Nipple

See page 35 section 9 for more Extension Configurations

9. Extension Material

S = Steel(Std) 4 = 304SS 6 = 316SS Z = Other

10. Extension Length "E" (Hex Nipple = .75 Inches)

11. Special Options (Choose all that apply)

N = None
 D = Universal Transmitter* (See Page 57)
 E = Economy Multi-input Transmitter* (Page 58)
 H = High Vibration
 I = SS ID Tag
 O = Separate Ungrounded Junctions
 P = Electro-etching
 S = Spring Loaded
 Y = Certificate of Conformance
 Z = Special (Consult Factory)

* Not available on all head styles

12. Thermowell Part number

Select a Thermowell from the Thermowell section (pages 53-54) and enter the part number here.

Style C – Spring Loaded Replacement Thermowell Element

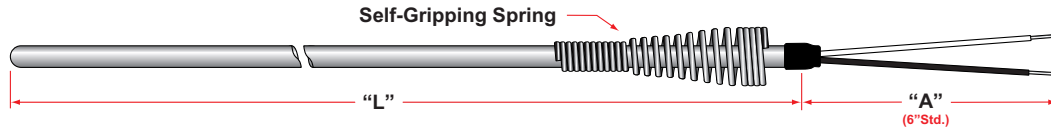

Spring Loaded Replacement Elements for Style U, Style T, and spring loaded Style H assemblies.



1. Calibration (See page 12 for other Cals)

J = Type J (1400°F) T = Type T (700°F)
K = Type K (2300°F) E = Type E (1600°F)

2. Junction

	Grounded	Ungrounded
Round Tip	G (Std)	U
Flat Tip	F	B
118° Drill Tip	D	C

3. Element Type

A = Single B = Duplex* C = Triplex*

* Common Ungrounded is Standard for Ungrounded Junctions
For Separated Ungrounded choose "O" under Special Options

4. Sheath Operating Temperature

A = -200°C to 260°C (500°F)(Std) D = 0°C to 600°C (1650°F)
B = -200°C to 400°C (750°F) E = 0°C to 1150°C (2100°F)
C = -200°C to 600°C (1200°F) Z = Other

5. Sheath Material (See page 13 for other Materials)

4 = 304SS (1650°F) 6 = 316SS (1650°F) I = INCONEL (2150°F)

6. Sheath Diameter

H = .188 I = .250(Std) M = .375

7. Sheath Length "L" (Example 12.5 = 12-1/2 inches)

1.75 - 99 inches Z = greater than 99 inches (Consult factory)

8. Leadwire Construction

	(solid wire)		(stranded wire)	
	Standard	Overbraid	Standard	Overbraid
Fiberglass (900°F)	A	F	C	H
Teflon® (400°F)	B	G	D	I
Kapton® (700°F)	E	J	Q	R

12. Special Options (Choose all that apply)

N = None
A = Special Limits of Error
G = Shielded leadwire
H = High Vibration
O = Separate Ungrounded Junctions
Q = Individual Leadwires (3/8" Strip Std)
R = Faster Response Construction
Y = Certificate of Conformance
7 = Rigid Tube Construction
Z = Special (Consult Factory)

11. Leadwire Terminations:

N = No Split/ No Strip (Std)
T = Split Leads (std = 2" split/3/8" strip)
U = Spade Lugs (std = 2" split)
V = Ring Lugs (std = 2" split)
W = 1/4 Push-on (std = 2" split)
Z = Special

10. Leadwire Length "A" (Example 12.5 = 12-1/2 inches)

9. Leadwire Gauge

A = 26 gauge B = 24 gauge C = 20 gauge (Std)

Also available in an RTD version. Go to

www.GICsensors.com

Protection Tube Thermocouples

Style P – Protection Tube Assembly

Style P - Protection Tube Assemblies are rugged heavy duty assemblies protected with industrial grade piping. Most commonly manufactured using ceramic insulators over base metal elements. But can also be produced with MgO sheath elements. Protection tube assemblies are used in many industrial and power applications.

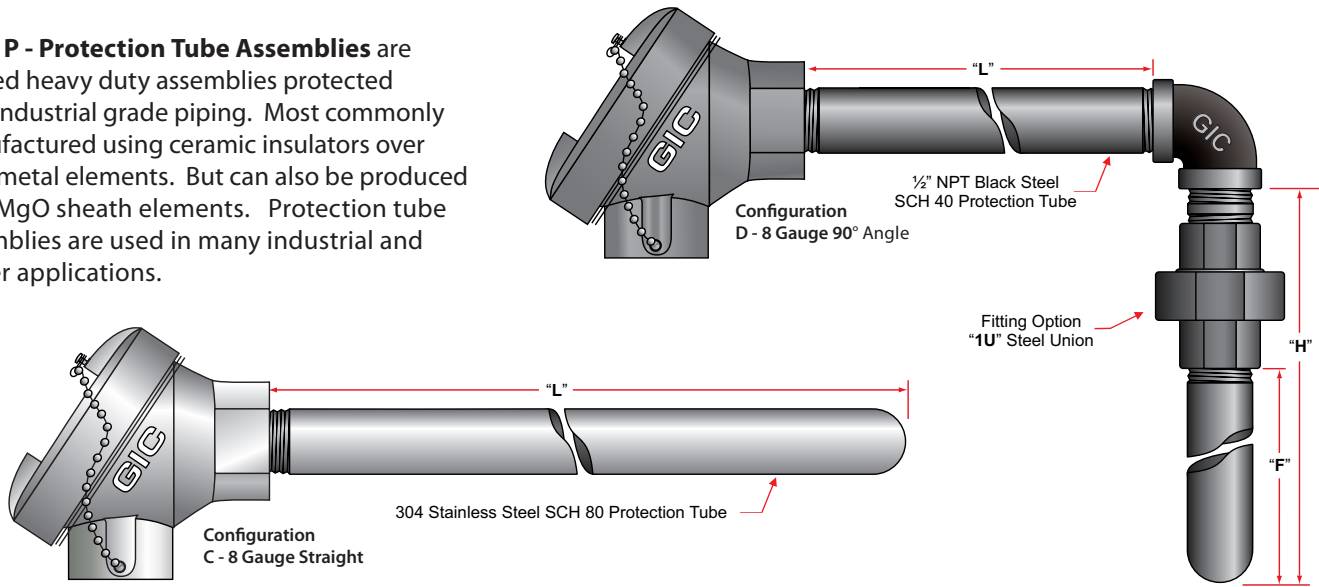

TP 1 - 2 3 4 N - 5 6 7 - N 8 N 9 - 10 11 12 - 13 - 14

1. Configuration
 C = 8 Gauge Straight
 D = 8 Gauge 90° Angle
 G = 14 Gauge Straight
 H = 14 Gauge 90° Angle
 (Consult Factory for other gauges)

2. Calibration (See page 12 for other Cals)
 J = Type J (1400°F) T = Type T (700°F)
 K = Type K (2300°F) E = Type E (1600°F)

3. Junction (See Diagram PT-J)

	Grounded	Ungrounded
Round Tip	G (Std)	U
Flat Tip	F	B
Exposed	-	E

4. Element Type
 A = Single B = Duplex*
 * Common Ungrounded is Standard for Ungrounded Junctions
 For Separated Ungrounded choose "O" under Special Options

5. Sheath Material (See page 13 for other Materials)
 B = Black Steel (Std) 4 = 304SS (1650°F)
 6 = 316SS (2150°F) I = INCONEL (2150°F)

6. Sheath Diameter (Consult Factory for other sizes)
 P = 1/2 NPT J = 3/4" NPT X = 1" NPT

7. Sheath Length "L"
 00 - 99 inches (Consult Factory for length over 99 Inches)

8. Pipe Schedule
 4 = Sch 40 Pipe 8 = Sch 80 Pipe Z = Special

9. Hot Length "H" (Use N for Straight Assemblies)
 Specify Length in Inches for Angled Assemblies
 N = Straight Assembly

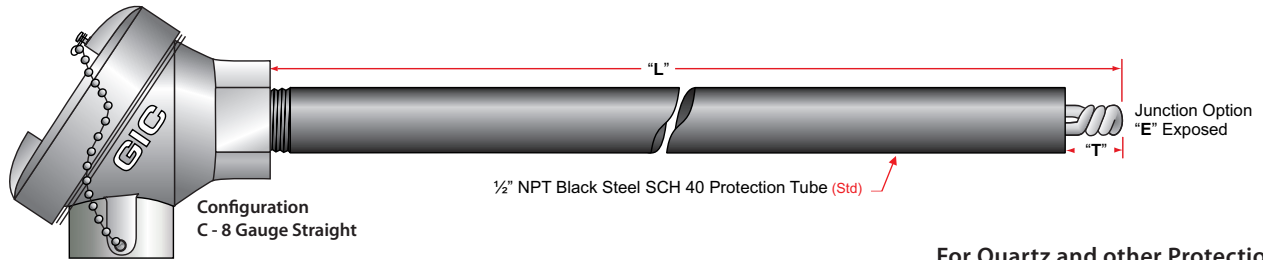

For Quartz and other Protection Tubes and Assemblies go to:
www.GICsensors.com

Diagram PT-J

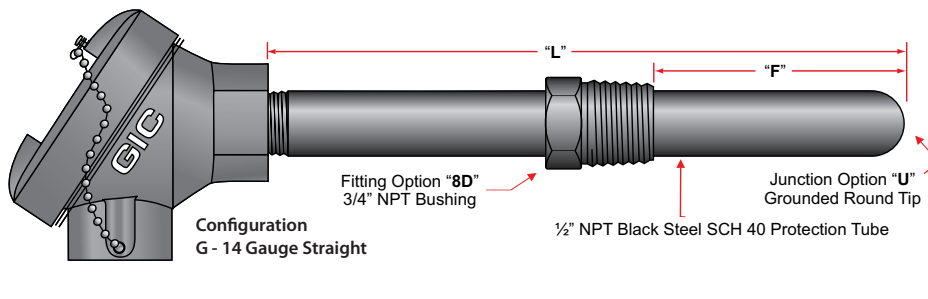
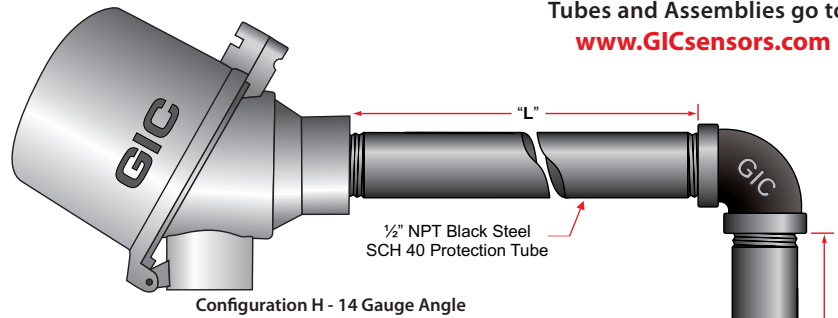
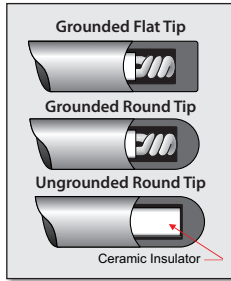

EXPOSED TIP STYLE ONLY

14. Exposed Length "T"
Specify Length in Inches

13. Special Options

N = None O = Separate Ungrounded Junctions
 A = Special Limits of Error U = Butt Welded Junction
 M = MgO Construction I = SS ID Tag

12. Fitting Location "F" (Example 12.5 = 12-1/2 Inches)

11. Fittings (Metric fittings also available)(Consult Factory for other sizes)

N = None (Std) 1U = Union (Stainless) 8U = Union (Steel) Z = Special

NPT Fittings	3/4" NPT	1" NPT	1-1/2" NPT	2" NPT	SPECIAL
Welded Bushing (Stainless)	1D	1B	1C	1D	1Z
Welded Bushing (Steel)	8D	2B	2C	2D	2Z

*Welded bushing must be at least one NPT size greater than sheath.

F = Flange (Fixed & Adjustable Flanges are available Consult Factory for sizes)

10. Connection Head (Consult Factory for other Heads)

A = Aluminum G = 316 Stainless Steel
 B = Cast Iron (Std) S = 316SS Explosion Proof
 C = FMCUS Alum. EXP V = Dan
 Y = APEX Aluminum EXP Z = Special

Connection Head Options

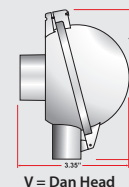
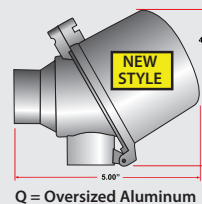
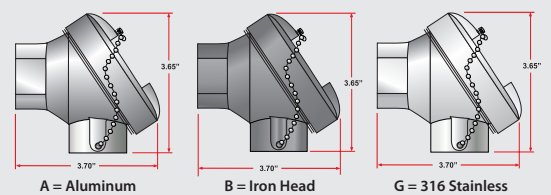

Connection Head Options Explosion Proof

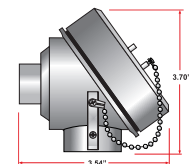

S = 316 Stainless Steel
 XDS-F: FMCUS Approved
 XDS-A: ATEX Approved
 C = Cast Aluminum
 XDA-F: FMCUS Approved
 Y = Cast Aluminum
 XDA-A: ATEX Approved

FMCUS (US & Canada) - meets all CSA standards & requirements Explosion Proof for Class I, Division 1, Groups A, B, C and D; and dust-ignition proof for Class II, III Division 1, Groups E, F & G, hazardous (classified) locations; indoor/ outdoor. Aluminum: NEMA 4, SS316: NEMA 4X6

Resistance Temperature Detectors (RTD)

RTD Assemblies

The principal of the Resistance Temperature Detector (RTD) is not nearly as complex as that of a thermocouple. Basically, the principal of operation depends on the fact that the electrical resistance of metals varies directly with temperature, and is reproducible to a high degree of accuracy. The curve of temperature versus resistance for a given wire material can thus be predicted by employing a constant, known as the temperature coefficient of resistance. Useful sensitive elements of RTD'S are those which show a resistance temperature relationship of acceptable magnitude. Two such metals are Platinum and Nickel.

RTD Accuracy.

RTD's are commonly used in sensitive areas requiring much tighter accuracy than thermocouples. But accuracy is dependent on the RTD leadwire configuration. Leadwire error can have a significant effect on accuracy. Adding leadwire between the RTD and control will add additional resistance to readings. Since resistance increases with temperature it is not recommended to use a 2-wire RTD when a high accuracy is required.

Configurations

2-wire configuration is the least accurate RTD configuration. The lead wire resistance is not compensated for by the transmitter or controller. The increased resistance will cause temperature to be higher than the actual temperature.

3-wire configuration is the most commonly used. The added lead wire resistance is calculated by the control through a third wire. The leadwire resistance is then subtracted from the loop resistance and true resistance is given. Through this method the controller or transmitter "compensates" the lead wire giving an accurate temperature display.

4-wire configuration provide slightly better compensation, but are generally found only in laboratory equipment and other areas where high accuracy is required but must be used in conjunction with a 4-wire instrument.

Construction

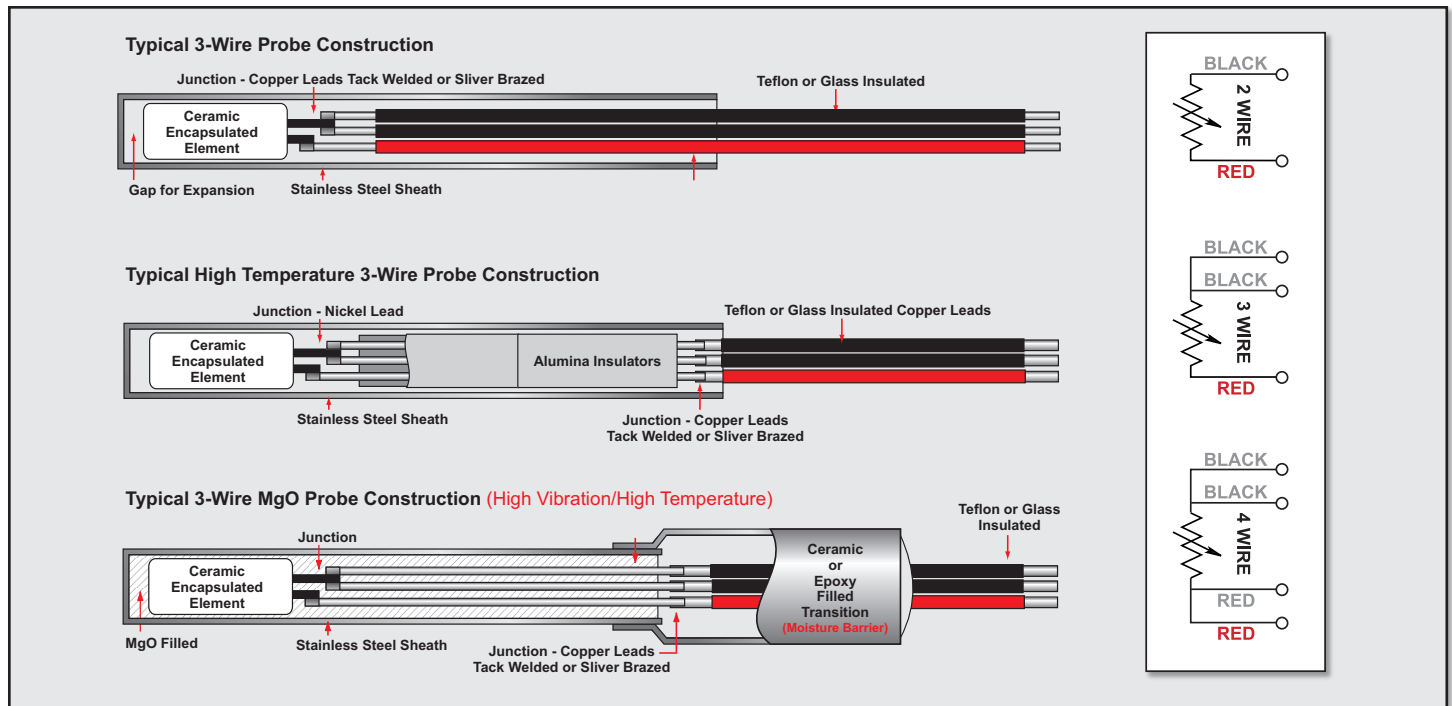

Considerations

GIC Thermodynamics' sales and engineering staff will assist you with designing the best RTD sensor style to fit your process and application. Selecting the proper sensor style is very important, as each application or process has its own specific inherent problems that require careful consideration in order to determine the sensors life, accuracy, and dependability. When choosing a sensor, it is important to consider its location, temperature range, accuracy required, how rapidly the temperature cycles, heat conduction, process environment, vibration, and ease of installation. If you need additional assistance with the selection of a sensor for your application, please feel free to contact our sales and engineering staff

Style A – Embedment Bearing Assembly

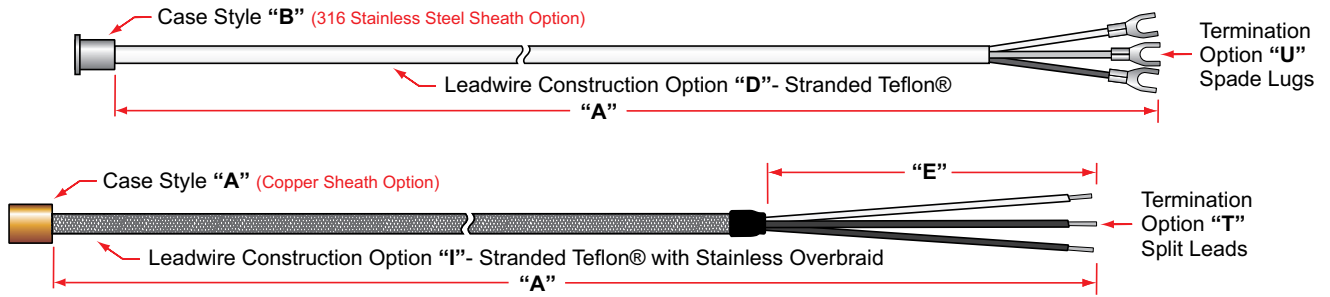

Style A - Embedment Assembly - Designed for monitoring bearing temperatures to provide advanced warning of lubrication oil breakdown before catastrophic bearing failure. Available in several case sizes, configurations and sheath materials. Standard operating range -32 to 266°F.

RA 1 - 2 **F** 3 **A** - 4 5 **N** - 6 7 8 - 9 10 - **N**

1. Case Style

A = Case A - 0.250" L, 0.275 Ø

B = Case B - 0.250" L, 0.188 Ø
0.250 Ø Flange

C = Case C - 0.300" L, 0.125 Ø

D = Case D - 0.250" L, 0.250 Ø

2. RTD Element Type

Material	Resistance	Temp. Coefficient
A = Platinum (Std)	100 ohms @ 0°C	.00385 ohm/ohm/°C
C = Platinum	500 ohms @ 0°C	.00385 ohm/ohm/°C
D = Platinum	1000 ohms @ 0°C	.00385 ohm/ohm/°C
G = Copper	10 ohms @ 25°C	.00427 ohm/ohm/°C

Tip Style / Element Accy.

F = Flat Tip ±0.10% at 0°C

3. Configuration (See Diagram RTD)

A = 2 Wire - Single Element	D = 4 Wire - Dual Element
B = 3 Wire - Single Element (Std)	E = 6 Wire - Dual Element
C = 4 Wire - Single Element	Z = Other

4. Sheath Material

4 = 304	6 = 316SS	C = Copper	B = Brass
K = Nickel Plated Copper	U = Tin Plated Copper		

5. Babbitt Tip

N = None B = Babbitt Tip (Styles A, B, and D only)
Reduces chance of overheating during installation

6. Leadwire Construction

<u>Stranded wire</u>	<u>Standard</u>	<u>Overbraid</u>	<u>Individual Leads</u>
Teflon® (400°F)	D (Std)	I	T

7. Leadwire Gauge

A = 26 gauge D = 30 gauge

8. Leadwire Length "A" (inches)

9. Leadwire Termination:

N = No Split/ No Strip
Q = Individual Leadwires
(3/8" Strip Std)
T = Split Leads (Std)
U = Spade Lugs
V = Ring Lugs
W = 1/4 Push-on
Z = Special

10. Split Length "E" (inches)

For additional bearing sensors please go to:
www.GICsensors.com

Resistance Temperature Detectors (RTD)

Style B – Basic Rigid Tube Assembly

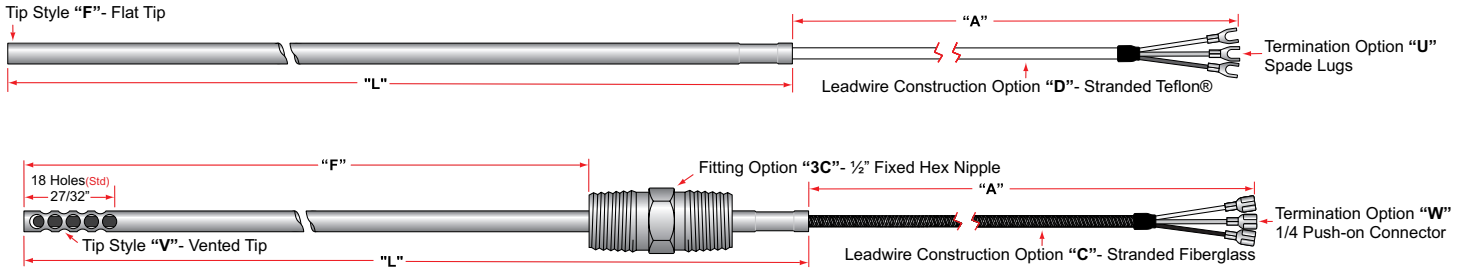

1. RTD Element Type

Material	Resistance	Temp. Coefficient
A = Platinum(Std)	100 ohms @ 0°C	.00385 ohm/ohm/°C
B = Platinum	100 ohms @ 0°C	.00392 ohm/ohm/°C
C = Platinum	500 ohms @ 0°C	.00385 ohm/ohm/°C
D = Platinum	1000 ohms @ 0°C	.00385 ohm/ohm/°C
F = Nickel	120 ohms @ 0°C	.00672 ohm/ohm/°C
G = Copper	10 ohms @ 25°C	.00427 ohm/ohm/°C
H = NiFe	604 ohms @ 0°C	.00519 ohm/ohm/°C

2. Tip Style / Element Accy. (See Diagram TS-RTD)

	.01%	.02%	.03%	.05%	.10%	.50%	1.00%
Flat Tip:	M	L	K	P	F(Std)	I	J
Round Tip:	H	E	D	A	G	B	C
Vented Tip:	Q	U	T	W	V	R	S

*Not all Accuracies are available for all element types

3. Configuration (See Diagram RTD)

A = 2 Wire - Single Element	D = 4 Wire - Dual Element
B = 3 Wire - Single Element(Std)	E = 6 Wire - Dual Element
C = 4 Wire - Single Element	Z = Other

4. Sheath Operating Temperature

A = -200°C to 260°C (500°F)(Std)	C = -200°C to 600°C (1200°F)
B = -200°C to 400°C (750°F)	Z = Other

5. Sheath Material (See page 13 for other Materials)

4 = 304SS (1650°F)(Std)	0 = 310SS (2100°F)
6 = 316SS (1650°F)	I = INCONEL (2150°F)

6. Sheath Diameter (Metric sizes also available)

G = .125*	I = .250*	M = .375	* Quick delivery
H = .188*	Q = .313	Z = Other	

7. Sheath Length "L" (Example 12.5 = 12-1/2 inches)

0.25 - 99.9 inches	Z = greater than 99.9 inches (Consult Factory)
--------------------	--

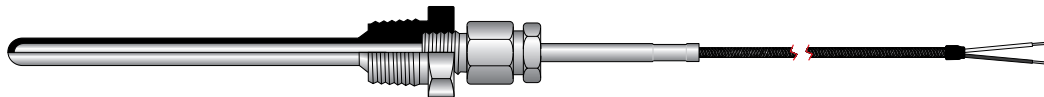

Shown Here with a Mini-Protection Tube and a compression fitting

The **Style B - Basic Rigid Tube Assembly**, with precise and repeatable readings over a full temperature span of -320F to 1200F, can be made in a variety of designs, including field bendable and cuttable. These RTDs cover the full temperature span of the international IEC-751 standards. They are durable, stable and provide the best accuracy over a long period of time.

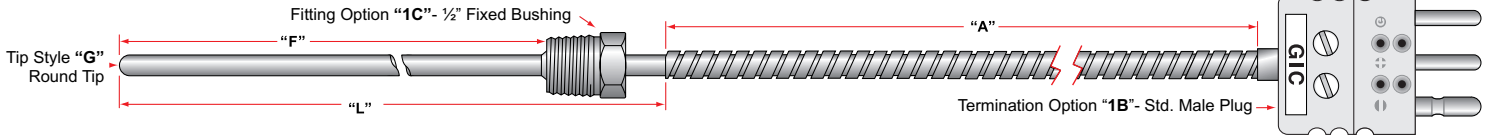

16. Bend Location "C" (inches from tip, see "Diagram BEND" page 19) N = No Bend (Std)

15. Bend Angle
 N = None(Std) G = 45 Degree Bend S = 90 Degree Bend Z = Other

14. Special Options

N = None (Std)	J = Coated Armor	Q = Individual Leadwires (3/8" Strip Std)
F = Field Bendable	L = Mating Connector	T = Coated Probe
G = Shielded leadwire	K = Copper Tip (Fast Response)	6 = Tip Sensitive Element
I = SS ID Tag	M = MgO Construction	Z = Other (Consult Factory)

13. Fitting Location "F" (inches from tip) N = No Fitting Location (Std)

12. Fittings (See page 15 for more info and other fittings) (Metric fittings also available)

N = None (Std) FB = Fixed Bayonet Fitting (.188 and .250 Dia only) Z = Special

NPT Fittings	1/8" NPT	1/4" NPT	1/2" NPT	3/4" NPT	SPECIAL
Fixed Bushing (Stainless)	1A	1B	1C	1D	1Z
Fixed Hex Nipple (Steel)	2A	2B	2C	2D	2Z
Fixed Hex Nipple (Stainless)	3A	3B	3C	3D	3Z
Spring Loaded Hex Nipple (Stainless)	-	-	4C	-	4Z
Compression (Brass) one time adj.	5A	5B	5C	-	5Z
Compression (Stainless) one time adj.	6A	6B	6C	-	6Z
Compression (Stainless) re-adjustable*	7A	7B	7C	-	7Z

*Teflon® gland standard (400°F) for other gland options such as Lava (1200°F) see page 15

11. Leadwire Terminations (See Diagram LT-RTD)

N = No Split/ No Strip(Std)
 T = Split Leads (std = 2" split/3/8" strip)
 U = Spade Lugs (std = 2" split)
 V = Ring Lugs (std = 2" split)
 W = 1/4 Push-on (std = 2" split)
 X = Bx Connector w/ #8 lugs
 Z = Other

PLUGS & JACKS	Std Temp (425°F)	
(2 and 3 wire only)	w/ clamp	w/o clamp
Std Male Plug	1A	1B
Std Female Jack	1C	1D
Mini Male Plug	1F	1G
Mini Female Jack	1H	1L

10. Leadwire Length "A" (Example 12.5 = 12-1/2 inches)

9. Leadwire Gauge
 A = 26 gauge (Std) B = 24 gauge C = 20 gauge (.125 Dia & .greater probes)

8. Leadwire Construction Z=Other

	Standard	Overbraid	Armor
Stranded wire			
Fiberglass (900°F)	C	H	O
Teflon® (400°F)	D (Std)	I	P
Kapton® (700°F)	Q	R	S

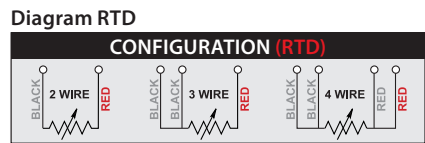
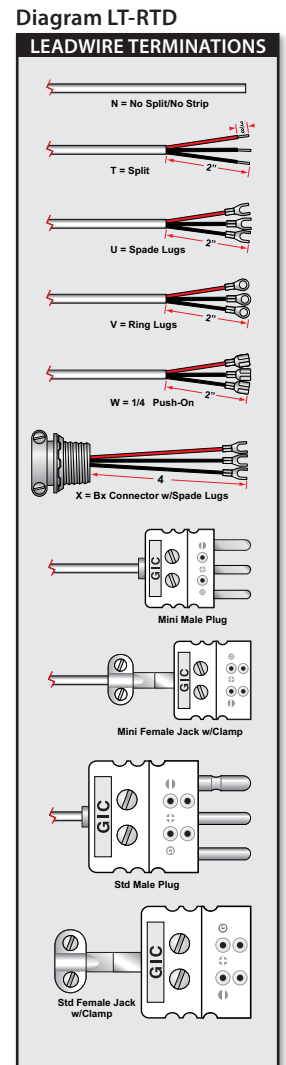
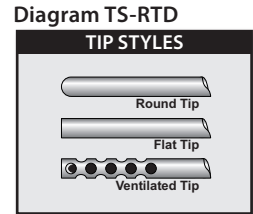

Resistance Temperature Detectors (RTD)

Style F – Transition Assembly

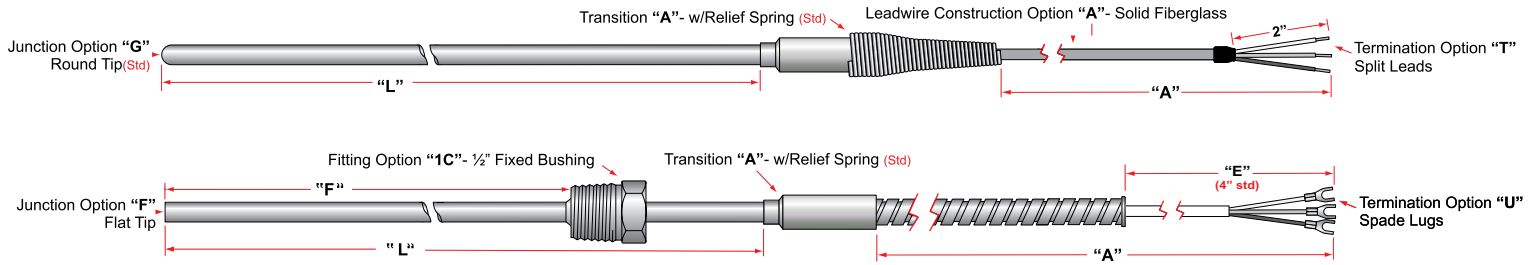

1. Transition (See page 15 for more Transitions)

- A = Standard Transition w/Relief Spring (500°F)(Std)
- B = Standard Transition (500°F)
- C = Hi-Temp Transition w/Relief Spring (1100°F)
- D = Hi-Temp Transition (1100°F)

2. RTD Element Type

Material	Resistance	Temp. Coefficient
A = Platinum(Std)	100 ohms @ 0°C	.00385 ohm/ohm/°C
B = Platinum	100 ohms @ 0°C	.00392 ohm/ohm/°C
C = Platinum	500 ohms @ 0°C	.00385 ohm/ohm/°C
D = Platinum	1000 ohms @ 0°C	.00385 ohm/ohm/°C
F = Nickel	120 ohms @ 0°C	.00672 ohm/ohm/°C
G = Copper	10 ohms @ 25°C	.00427 ohm/ohm/°C
H = NiFe	604 ohms @ 0°C	.00519 ohm/ohm/°C

3. Tip Style / Element Accy. (See Diagram TS-RTD)

	.01%	.02%	.03%	.05%	.10%	.50%	1.00%
Flat Tip:	M	L	K	P	F(Std)	I	J
Round Tip:	H	E	D	A	G	B	C
Vented Tip:	Q	U	T	W	V	R	S

*Not all Accuracies are available for all element types

4. Configuration (See Diagram RTD)

- A = 2 Wire - Single Element
- B = 3 Wire - Single Element(Std)
- C = 4 Wire - Single Element
- D = 4 Wire - Dual Element
- E = 6 Wire - Dual Element
- Z = Other

5. Sheath Operating Temperature

- A = -200°C to 260°C (500°F)(Std)
- B = -200°C to 400°C (750°F)
- C = -200°C to 600°C (1200°F)
- Z = Other

6. Sheath Material (See page 13 for other Materials)

- 4 = 304SS (1650°F)(Std)
- 6 = 316SS (1650°F)
- 0 = 310SS (2100°F)
- I = INCONEL (2150°F)

7. Sheath Diameter (Metric sizes also available)

- G = .125* I = .250* M = .375
 - H = .188* Q = .313 Z = Other
- * Quick delivery

8. Sheath Length "L" (Example 12.5 = 12-1/2 inches)

- 0.25 - 99.9 inches
- Z = greater than 99.9 inches (Consult Factory)

The **Style F - Transition Assembly** is one of the most universal of all RTD assemblies. It can be adapted to most applications where temperature measurement is required. It is available in a variety of lengths, sheath materials, leadwire insulations & terminations. The MgO construction option is a great choice for High Vibration applications.

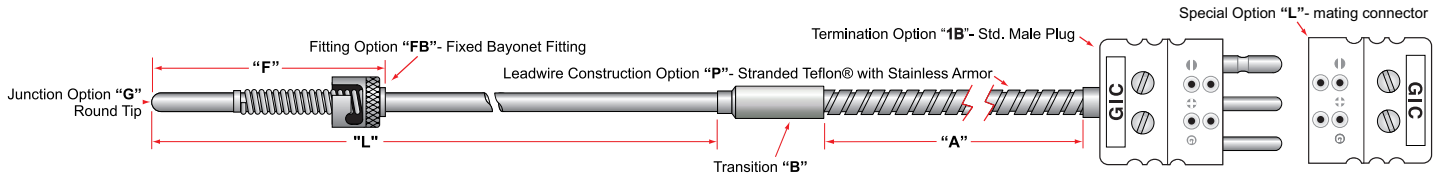

17. Bend Location "C" (inches from tip, see "Diagram BEND" page 19) N = No Bend (Std)

16. Bend Angle
 N = None(Std) G = 45 Degree Bend S = 90 Degree Bend Z = Other

15. Special Options

N = None (Std)	J = Coated Armor	T = Coated Probe
F = Field Bendable	K = Copper Tip (Fast Response)	Y = Certificate of Conformance
H = High-Vibration	L = Mating Connector	6 = Tip Sensitive Element
I = SS ID Tag	M = MgO Construction	Z = Other (Consult Factory)

14. Fitting Location "F" (inches from tip) N = No Fitting Location (Std)

13. Fittings (See page 15 for more info and other fittings) (Metric fittings also available)

NPT Fittings	1/8" NPT	1/4" NPT	1/2" NPT	3/4" NPT	SPECIAL
Fixed Bushing (Stainless)	1A	1B	1C	1D	1Z
Fixed Hex Nipple (Steel)	2A	2B	2C	2D	2Z
Fixed Hex Nipple (Stainless)	3A	3B	3C	3D	3Z
Spring Loaded Hex Nipple (Stainless)	-	-	4C	-	4Z
Compression (Brass) one time adj.	5A	5B	5C	-	5Z
Compression (Stainless) one time adj.	6A	6B	6C	-	6Z
Compression (Stainless) re-adjustable*	7A	7B	7C	-	7Z

*Teflon® gland standard (400°F) for other gland options such as Lava (1200°F) see page 15

12. Leadwire Terminations (See Diagram LT-RTD)

Termination	PLUGS & JACKS	Std Temp (425°F)
N = No Split/ No Strip(Std)		w/ clamp w/o clamp
T = Split Leads (std = 2" split/3/8" strip)	Std Male Plug	1A 1B
U = Spade Lugs (std = 2" split)	Std Female Jack	1C 1D
V = Ring Lugs (std = 2" split)	Mini Male Plug	1F 1G
W = 1/4 Push-on (std = 2" split)	Mini Female Jack	1H 1L
X = Bx Connector w/ #8 lugs		
Z = Other		

11. Leadwire Length "A" (Example 12.5 = 12-1/2 inches)

10. Leadwire Gauge
 A = 26 gauge (Std) B = 24 gauge C = 20 gauge (.125 Dia & .greater probes)

9. Leadwire Construction Z = Other

Leadwire	Standard	Overbraided	Armor
Fiberglass (900°F)	C	H	O
Teflon® (400°F)	D (Std)	I	P
Kapton® (700°F)	Q	R	S

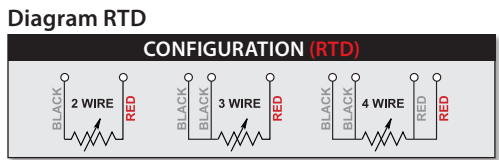
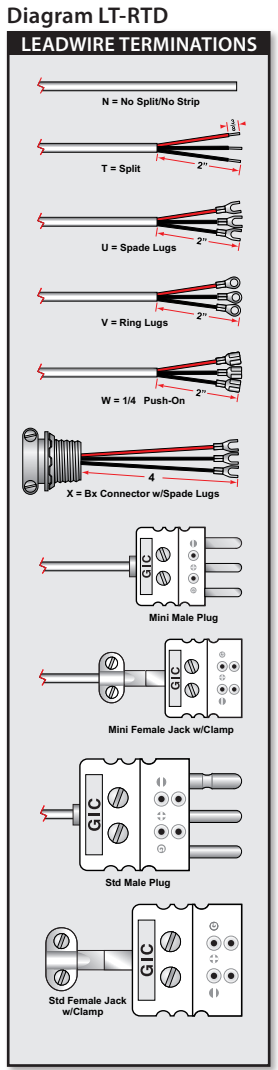
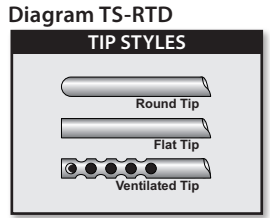

Resistance Temperature Detectors (RTD)

Style D – Quick Disconnect Assembly

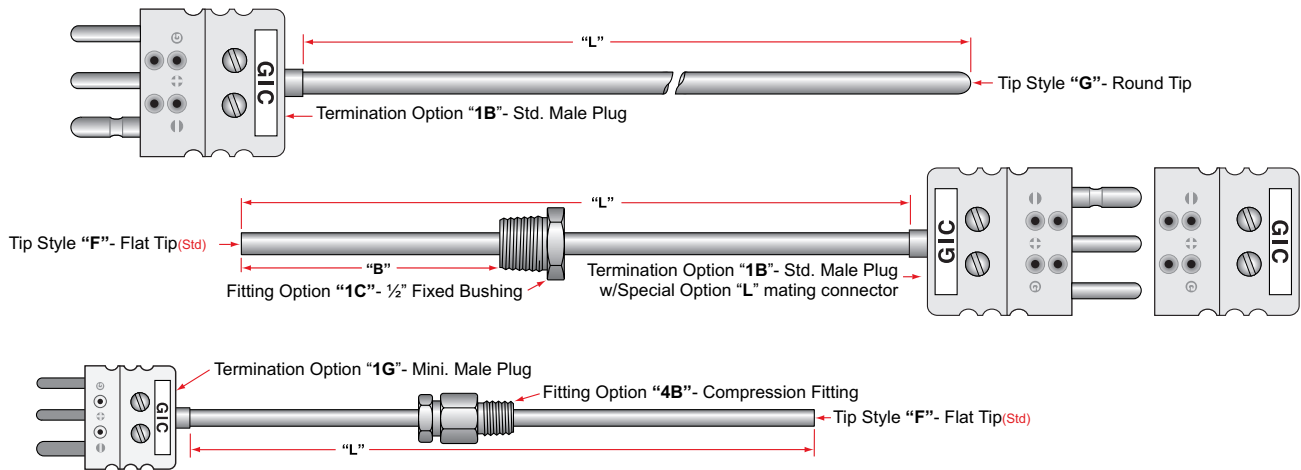

1. RTD Element Type

Material	Resistance	Temp. Coefficient
A = Platinum (Std)	100 ohms @ 0°C	.00385 ohm/ohm/°C
B = Platinum	100 ohms @ 0°C	.00392 ohm/ohm/°C
C = Platinum	500 ohms @ 0°C	.00385 ohm/ohm/°C
D = Platinum	1000 ohms @ 0°C	.00385 ohm/ohm/°C
F = Nickel	120 ohms @ 0°C	.00672 ohm/ohm/°C
G = Copper	10 ohms @ 25°C	.00427 ohm/ohm/°C
H = NiFe	604 ohms @ 0°C	.00519 ohm/ohm/°C

2. Tip Style / Element Accy. (See Diagram TS-RTD)

	.01%	.02%	.03%	.05%	.10%	.50%	1.00%
Flat Tip:	M	L	K	P	F (Std)	I	J
Round Tip:	H	E	D	A	G	B	C
Vented Tip:	Q	U	T	W	V	R	S

*Not all Accuracies are available for all element types

3. Configuration (See Diagram RTD)

A = 2 Wire - Single Element	D = 4 Wire - Dual Element
B = 3 Wire - Single Element (Std)	Z = Other

4. Sheath Operating Temperature

A = -200°C to 260°C (500°F) (Std)	C = -200°C to 600°C (1200°F)
B = -200°C to 400°C (750°F)	Z = Other

5. Sheath Material (See page 13 for other Materials)

4 = 304SS (1650°F) (Std)	0 = 310SS (2100°F)
6 = 316SS (1650°F)	I = INCONEL (2150°F)

6. Sheath Diameter (Metric sizes also available)

G = .125*	I = .250*	M = .375	* available for quick delivery
H = .188*	Q = .313	Z = Other	

7. Sheath Length "L" (Example 12.5 = 12-1/2 inches)

0.25 - 99.9 inches	Z = greater than 99.9 inches (Consult Factory)
--------------------	--

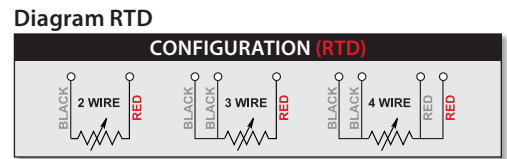

Diagram BEND

INFORMATION FOR ORDERING A SENSOR WITH A BEND

Bending info for all Sheath Thermocouples and RTD's in this catalog

Factory Bend Standards:

For 45° degree bends "C" is measured from the tip to the start of the bend.

For 90° degree bends "C" is measured from the tip to the centerline of the sheath.

For Bends other than 45° or 90° consult factory.

Chart - RD

SHEATH DIAMETER	BEND RADIUS
1/8" (.125)	3/8" Radius
3/16" (.188)	7/16" Radius
1/4" (.250)	9/16" Radius
3/8" (.375)	15/16" Radius
1/2" (.500)	1-1/2" Radius

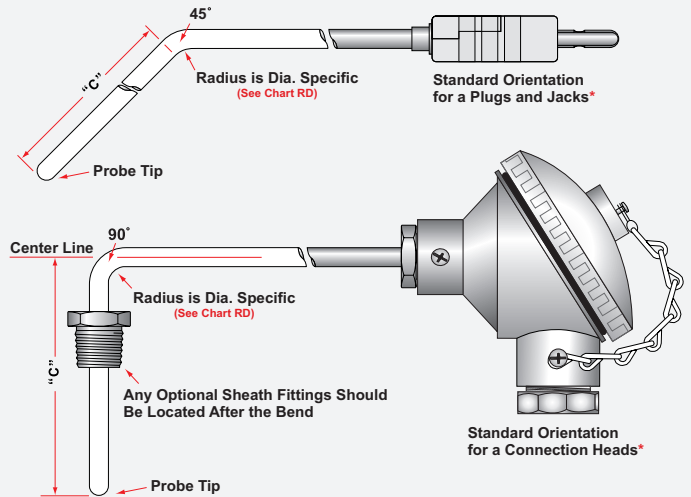

Notes:

For RTD's the minimum "C" dimension is the length of the element plus 1/2".

*For orientations of terminations other than standard consult factory.

13. Bend Location "C" (Inches from tip, see "Diagram BEND") N = No Bend (Std)

12. Bend Angle N = None(Std) G = 45 Degree Bend S = 90 Degree Bend Z = Other

11. Special Options (Choose all that apply)

N = None	M = MgO Construction
F = Field Bendable	T = Coated Probe
H = High Vibration	Y = Certificate of Conformance
K = Copper Tip	6 = Tip Sensitive Element
L = Mating Connector	Z = Other (Consult Factory)

10. Fitting Location "F" (Inches from tip) N = No Fitting Location (Std)

9. Fittings (See page 15 for more info and other fittings) (Metric fittings also available)

N = None (Std) FB = Fixed Bayonet Fitting (.188 and .250 Dia only) Z = Special

NPT Fittings	1/8" NPT	1/4" NPT	1/2" NPT	3/4" NPT	SPECIAL
Fixed Bushing (Stainless)	1A	1B	1C	1D	1Z
Compression (Brass) one time adj.	5A	5B	5C	-	5Z
Compression (Stainless) one time adj.	6A	6B	6C	-	6Z
Compression (Stainless) re-adjustable*	7A	7B	7C	-	7Z

*Teflon® gland standard (400°F) for other gland options such as Lava (1200°F) see page 15

8. Terminations

PLUGS & JACKS

- 1B = Std Male Plug (425°F)
- 1D = Std Female Jack (425°F)
- 1G = Mini Male Plug (425°F)
- 1L = Mini Female Jack (425°F)

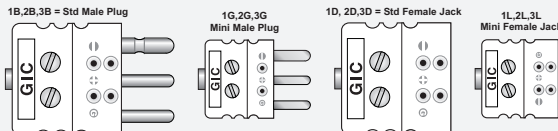

Resistance Temperature Detectors (RTD)

Style H – Connection Head Assembly

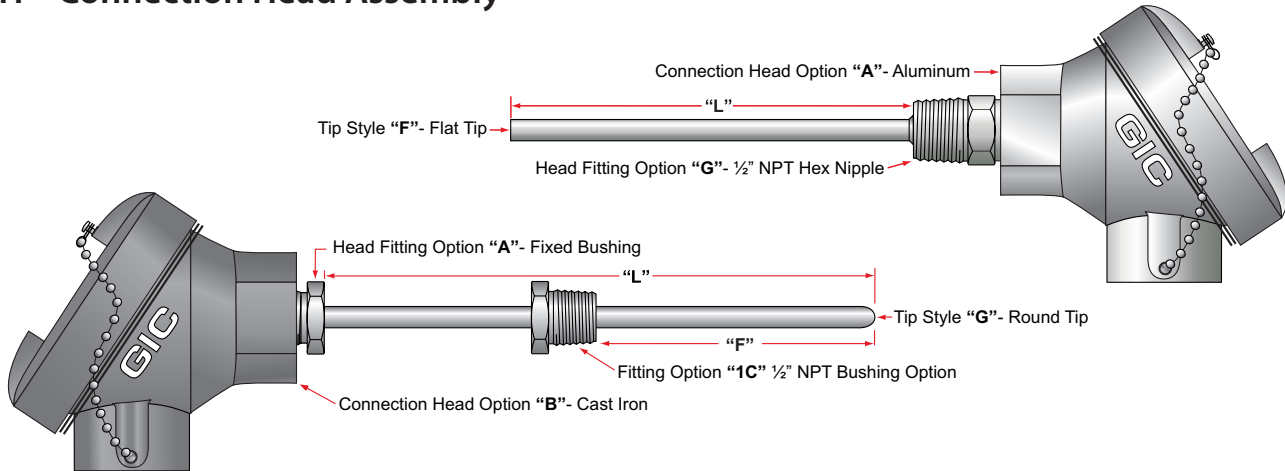

1. Connection Head

A = Aluminum	G = 316 Stainless Steel
B = Cast Iron	S = 316SS Explosion Proof
C = FMCUS Alum. EXP	V = Dan
D = Poly Black - Chain	Y = APEX Aluminum EXP
E = FDA Ploy - Latch	(Consult Factory for Specialty)

2. RTD Element Type

Material	Resistance	Temp. Coefficient
A = Platinum(Std)	100 ohms @ 0°C	.00385 ohm/ohm/°C
B = Platinum	100 ohms @ 0°C	.00392 ohm/ohm/°C
C = Platinum	500 ohms @ 0°C	.00385 ohm/ohm/°C
D = Platinum	1000 ohms @ 0°C	.00385 ohm/ohm/°C
F = Nickel	120 ohms @ 0°C	.00672 ohm/ohm/°C
G = Copper	10 ohms @ 25°C	.00427 ohm/ohm/°C
H = NiFe	604 ohms @ 0°C	.00519 ohm/ohm/°C

3. Tip Style / Element Accy. (See Diagram TS-RTD)

	.01%	.02%	.03%	.05%	.10%	.50%	1.00%
Flat Tip:	M	L	K	P	F(Std)	I	J
Round Tip:	H	E	D	A	G	B	C
Vented Tip:	Q	U	T	W	V	R	S

*Not all Accuracies are available for all element types

4. Configuration (See Diagram RTD)

A = 2 Wire - Single Element	D = 4 Wire - Dual Element*
B = 3 Wire - Single Element(Std)	E = 6 Wire - Dual Element*
C = 4 Wire - Single Element	Z = Other

* Not available for all head styles

5. Sheath Operating Temperature

A = -200°C to 260°C (500°F)(Std)	C = -200°C to 600°C (1200°F)
B = -200°C to 400°C (750°F)	Z = Other

6. Sheath Material (See page 13 for other Materials)

4 = 304SS (1650°F)(Std)	0 = 310SS (2100°F)
6 = 316SS (1650°F)	I = INCONEL (2150°F)

7. Sheath Diameter (Metric sizes also available)

G = .125*	I = .250*	M = .375
H = .188*	Q = .313	Z = Other * Quick delivery

CONNECTION HEAD OPTIONS

A = Aluminum **B = Iron Head** **C = Cast Aluminum EP**
S = 316 Stainless Steel EP **H = FDA Poly - Chain**
D = Black Poly - Chain **E = FDA Poly - Latch** **F = Nylon Head**

G = 316 Stainless **M = Alum. Miniature** **O = Open Ceramic Block** **Q = Nylon Miniature** **R = Canister** **Q = Oversized Aluminum** **V = Dan Head**

For more Connection Head options go to www.GICthermodynamics.com

14. Bend Location "C" (inches from tip, see "Diagram BEND" page 47) **N = No Bend (Std)**

13. Bend Angle (See Page 47 for more information)
N = None(Std) **G = 45 Degree Bend** **S = 90 Degree Bend** **Z = Other**

12. Special Options

N = None **P = Electro-etching**
B = RTD Transmitter* (See page 58) **S = Spring Loaded**
C = Programmable Transmitter* (See page 58) **T = Coated Probe**
H = High Vibration **Y = Certificate of Conformance**
K = Copper Tip **6 = Tip Sensitive Element**
I = SS ID Tag **Z = Special (Consult Factory)**
M = MgO Construction * Not available for all head styles

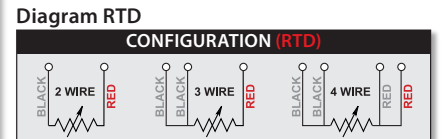

11. Fitting Location "F" (inches from tip) **N = No Fitting Location (Std)**

10. Fittings (See page 15 for more info and other fittings) (Metric fittings also available)
N = None (Std) **FB = Fixed Bayonet Fitting (.188 and .250 Dia only)** **Z = Special**

NPT Fittings	1/8" NPT	1/4" NPT	1/2" NPT	SPECIAL
Fixed Bushing (Stainless)	1A	1B	1C	1Z
Compression (Brass) one time adj.	5A	5B	5C	5Z
Compression (Stainless) one time adj.	6A	6B	6C	6Z
Compression (Stainless) re-adjustable*	7A	7B	7C	7Z

*Teflon® gland standard (400°F) for other gland options such as Lava (1200°F) see page 15

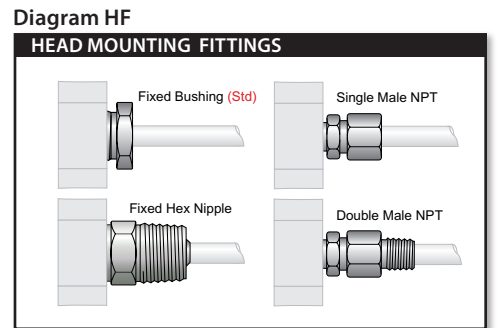

9. Head Mounting Fittings (See Diagram HF)

A = Fixed Bushing (No process threads) (Stainless) (Std) **P = Pipe Nipple (specify in notes)** **N = None** **Z = Special**

Hex Nipple Connection	1/4" NPT	1/2" NPT	3/4" NPT	Compression Fitting Connection	1/8" NPT	1/4" NPT	1/2" NPT
Fixed Hex Nipple (Steel)	F	G	H	Single Male NPT (Stainless)	-	-	S
Fixed Hex Nipple (Stainless)	I	J	K	Double Male NPT (Stainless)	W	X	Y

8. Sheath Length "L" (Example 12.5 = 12-1/2 inches)
 0.25 - 99.9 inches **Z = greater than 99.9 inches (Consult Factory)**

For a larger selection of RTD Assemblies go to: www.GICthermodynamics.com

RTD's for Existing Thermowells

Style T – Connection Head Assembly For Wells and Protection Tubes

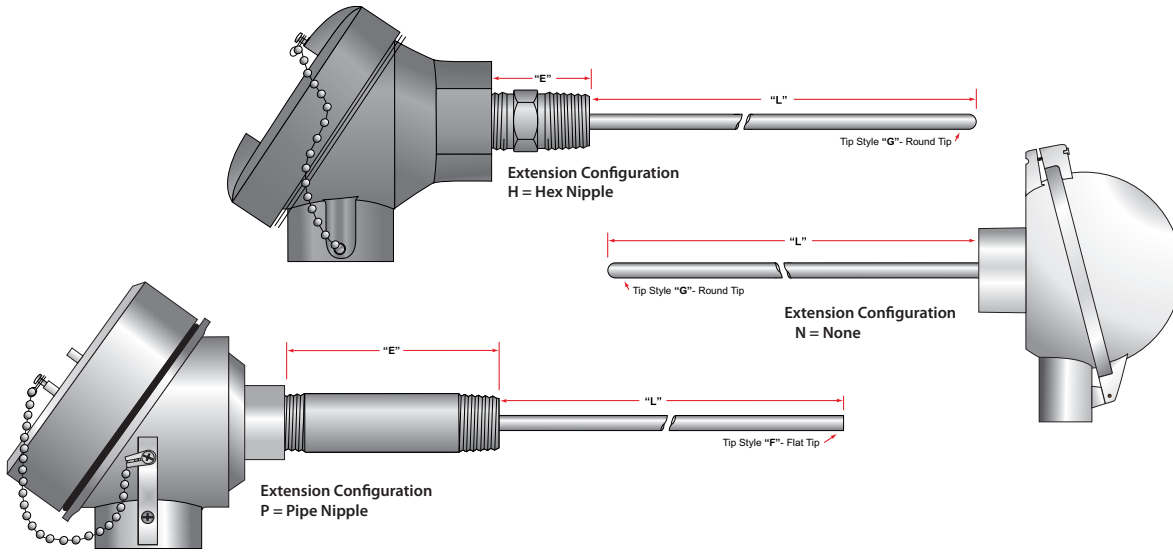

1. Connection Head

A = Aluminum G = 316 Stainless Steel
 B = Cast Iron S = 316SS Explosion Proof
 C = FMCUS Alum. EXP V = Dan
 D = Poly Black - Chain Y = APEX Aluminum EXP
 E = FDA Ploy - Latch (Consult Factory for Specialty Heads)

2. RTD Element Type

Material	Resistance	Temp. Coefficient
A = Platinum(Std)	100 ohms @ 0°C	.00385 ohm/ohm/°C
B = Platinum	100 ohms @ 0°C	.00392 ohm/ohm/°C
C = Platinum	500 ohms @ 0°C	.00385 ohm/ohm/°C
D = Platinum	1000 ohms @ 0°C	.00385 ohm/ohm/°C
F = Nickel	120 ohms @ 0°C	.00672 ohm/ohm/°C
G = Copper	10 ohms @ 25°C	.00427 ohm/ohm/°C
H = NiFe	604 ohms @ 0°C	.00519 ohm/ohm/°C

3. Tip Style / Element Accy. (See Diagram TS-RTD)

	.01%	.02%	.03%	.05%	.10%	.50%	1.00%
Flat Tip:	M	L	K	P	F(Std)	I	J
Round Tip:	H	E	D	A	G	B	C
Vented Tip:	Q	U	T	W	V	R	S

*Not all Accuracies are available for all element types

4. Configuration (See Diagram RTD)

A = 2 Wire - Single Element D = 4 Wire - Dual Element*
 B = 3 Wire - Single Element(Std) E = 6 Wire - Dual Element*
 C = 4 Wire - Single Element * Not available for all head styles

Z = Other

5. Sheath Operating Temperature

A = -200°C to 260°C (500°F)(Std) C = -200°C to 600°C (1200°F)
 B = -200°C to 400°C (750°F) Z = Other

6. Sheath Material (See page 13 for other Materials)

4 = 304SS (1650°F)(Std) 0 = 310SS (2100°F)
 6 = 316SS (1650°F) I = INCONEL (2150°F)

Connection Head Options - Explosion Proof

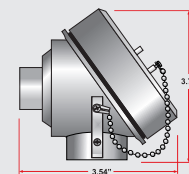

S = 316 Stainless Steel
 XDS-F: FMCUS Approved
 XDS-A: ATEX Approved

C = Cast Aluminum
 XDA-F: FMCUS Approved

Y = Cast Aluminum
 XDA-A: ATEX Approved

FMCUS (US & Canada) - meets all CSA standards & requirements Explosion Proof for Class I, Division 1, Groups A, B, C and D; and dust-ignition proof for Class II, III Division 1, Groups E, F and G, hazardous (classified) locations; indoor/ outdoor Aluminum: NEMA 4 SS316: NEMA 4X6

Style T – RTD’S for Thermowells and Protection Tubes

Style T - RTD Thermowell Assemblies are 1/4" and 3/8" OD sensors meant to be used with existing .260" ID and .385" ID thermowells or Protection tubes.

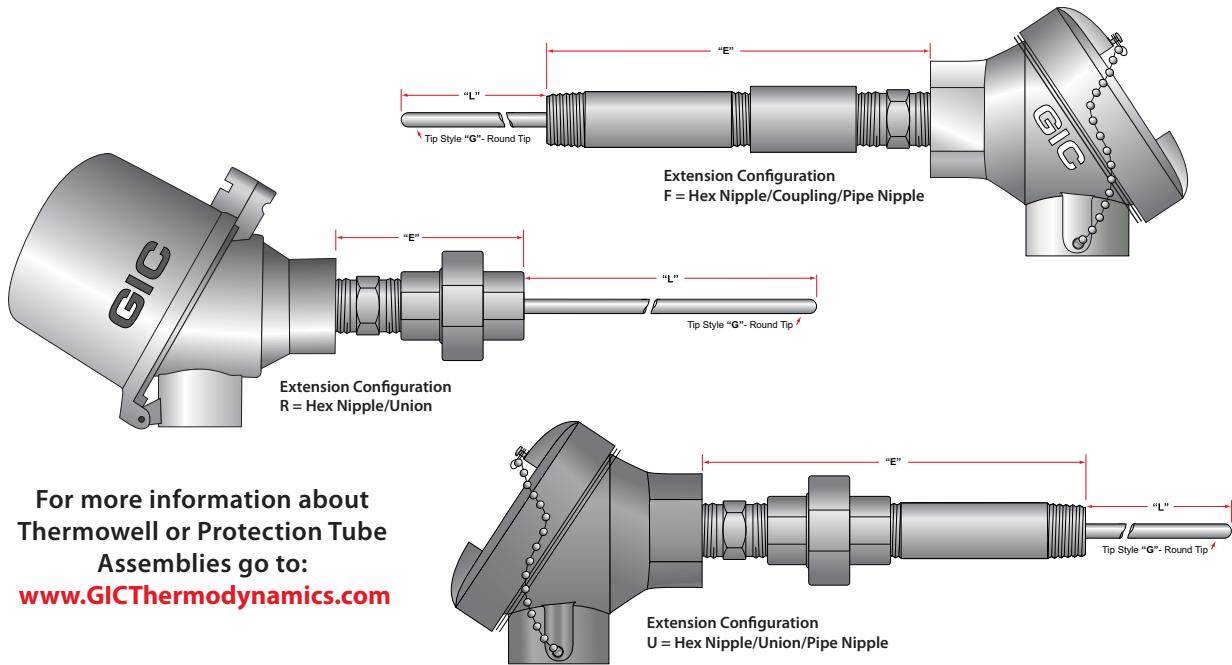

For more information about Thermowell or Protection Tube Assemblies go to:
www.GICThermodynamics.com

Diagram PT-PIPE

Nominal Pipe Size	Outside Diameter	Sch 40 Wall Thickness	Sch 80 Wall Thickness
1/8"	0.405"	0.068"	0.095
1/4"	0.540"	0.088"	0.119
3/8"	0.675"	0.091"	0.129
1/2"	0.840"	0.109"	0.147
3/4"	1.050"	0.113"	0.154
1"	1.315"	0.133"	0.179
1-1/4"	1.660"	0.140"	0.191
1-1/2"	1.900"	0.145"	0.200
2"	2.375"	0.154"	0.218

12. Special Options

- N = None
 - B = RTD Transmitter* (See page 58)
 - C = Programmable Transmitter* (See page 58)
 - H = High Vibration
 - K = Copper Tip (600°F)
 - I = SS ID Tag
 - M = MgO Construction
 - P = Electro-etching
 - S = Spring Loaded
 - Y = Certificate of Conformance
 - 6 = Tip Sensitive Element
 - Z = Other (Consult Factory)
- * Not available for all head styles

11. Extension Length "E" (Example 12.5 = 12-1/2 Inches)

10. Extension Material

- S = Steel(Std)
- 4 = 304SS
- 6 = 316SS
- Z = Other

9. Extension configuration

- H = Hex Nipple
 - R = Hex Nipple/Union
 - U = Hex Nipple/Union/Pipe Nipple
 - W = Hex Nipple/Union/Hex Nipple*
 - P = Pipe Nipple
 - S = Pipe Nipple/Union
 - T = Pipe Nipple/Union/Hex Nipple
 - V = Pipe Nipple/Union/Pipe Nipple*
 - C = Hex Nipple/Coupling
 - D = Pipe Nipple/Coupling
 - F = Hex Nipple/Coupling/Pipe Nipple
 - G = Pipe Nipple/Coupling/Hex Nipple
- N = None
- * (If this option is chosen then at least one of the pipe nipples lengths will have to be call out in the notes.)

8. Sheath Length "L" (Example 012= 12 inches)

00 - 99.9 inches ZZ = greater than 99 inches - consult Factory

7. Sheath Diameter

- I = .250
- M = .375
- Z = Other

Diagram RTD

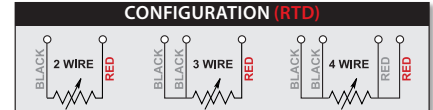

For more Connection Head options go to www.GICThermodynamics.com

Connection Head Options

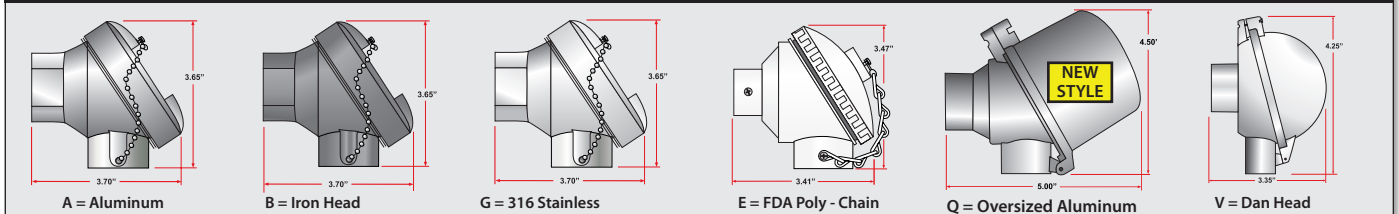

Resistance Temperature Detectors (RTD)

Style U – RTD Thermowell Assembly

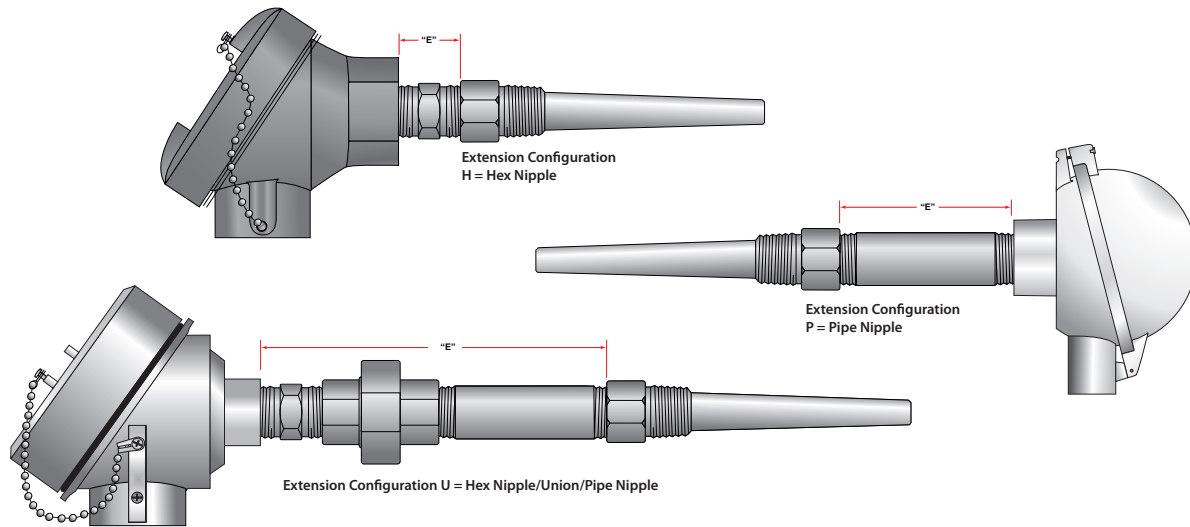

RU 1 - 2 3 4 5 - 6 7 -N- 8 9 10 - 11 - Thermowell Part Number 12

1. Connection Head

A = Aluminum G = 316 Stainless Steel
 B = Cast Iron S = 316SS Explosion Proof
 C = FMCUS Alum. EXP V = Dan
 D = Poly Black - Chain Y = APEX Aluminum EXP
 E = FDA Ploy - Latch (Consult Factory for Specialty Heads)

2. RTD Element Type

Material	Resistance	Temp. Coefficient
A = Platinum (Std)	100 ohms @ 0°C	.00385 ohm/ohm/°C
B = Platinum	100 ohms @ 0°C	.00392 ohm/ohm/°C
C = Platinum	500 ohms @ 0°C	.00385 ohm/ohm/°C
D = Platinum	1000 ohms @ 0°C	.00385 ohm/ohm/°C
F = Nickel	120 ohms @ 0°C	.00672 ohm/ohm/°C
G = Copper	10 ohms @ 25°C	.00427 ohm/ohm/°C
H = NiFe	604 ohms @ 0°C	.00519 ohm/ohm/°C

3. Tip Style / Element Accy. (See Diagram TS-RTD)

	.01%	.02%	.03%	.05%	.10%	.50%	1.00%
Flat Tip:	M	L	K	P	F(Std)	I	J
Round Tip:	H	E	D	A	G	B	C

*Not all Accuracies are available for all element types

4. Configuration (See Diagram RTD)

A = 2 Wire - Single Element D = 4 Wire - Dual Element*
 B = 3 Wire - Single Element(Std) E = 6 Wire - Dual Element*
 C = 4 Wire - Single Element * Not available for all head styles

5. Sheath Operating Temperature

A = -200°C to 260°C (500°F)(Std) C = -200°C to 600°C (1200°F)
 B = -200°C to 400°C (750°F) Z = Other

6. Sheath Material (See page 13 for other Materials)

4 = 304SS (1650°F)(Std) 0 = 310SS (2100°F)
 6 = 316SS (1650°F) I = INCONEL (2150°F)

7. Sheath Diameter

I = .250 M = .375 Consult factory for other diameters

12. Thermowell Part number

Select a Thermowell from the Thermowell section (pages 53-54) and enter the part number here.

11. Special Options (Choose all that apply)

N = None
 B = RTD Transmitter* (See page 58)
 C = Programmable Transmitter* (See page 58)
 H = High Vibration
 I = SS ID Tag
 M = MgO Construction
 P = Electro-etching
 S = Spring Loaded
 Y = Certificate of Conformance
 Z = Special (Consult Factory) * Not available on some head styles

10. Extension Length "E" (Hex Nipple = .75 Inches)

9. Extensions Material

S = Steel(Std) 4 = 304SS 6 = 316SS Z = Other

8. Extension configuration

H = Hex Nipple
 P = Pipe Nipple
 U = Hex Nipple/Union/Pipe Nipple

Standard Threaded Thermowells for 1/4" and 3/8" Sensors

GIC offers thermowells to meet demanding conditions such as corrosion, pressure and high temperature. Thermowells from drilled bar - stock result in pressure-tight seals that provide the required protection.

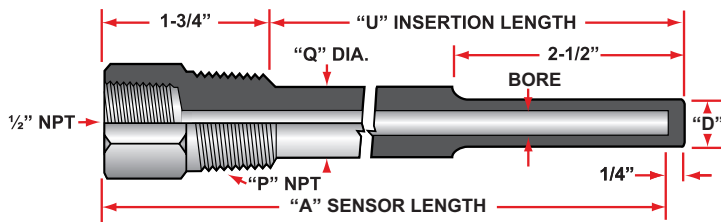

GIC can supply any size or configuration of Thermowell. For Custom wells consult the factory or visit us on the web at www.GICthermodynamics.com

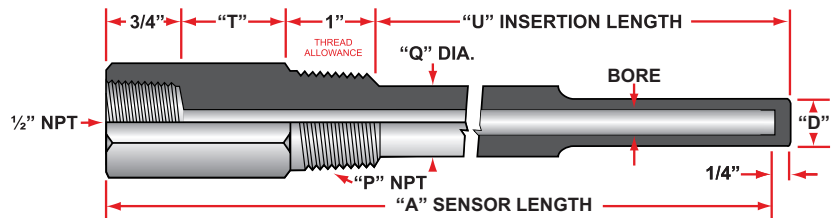

1. Well Bore Dia.
260 = For 1/4" Dia. Sensors
385 = For 3/8" Dia. Sensors

2. Process Connection "P"
A = 1/2" NPT B = 3/4" NPT C = 1" NPT

3. Sensor Length "A" (See Chart)
06 = 6" 12 = 12" 18 = 18"
09 = 9" 15 = 15" 24 = 24"

4. Lagging
N = Non-Lagging
L = Lagging

5. Special Options
N = None
1 = Brass Well Cap and Chain
4 = 304SS Well Cap and Chain
6 = 316SS Well Cap and Chain
Z = Other (Consult Factory)

6. Well Material
1 = Brass
2 = Carbon Steel
4 = A.I.S.I. - 304SS
6 = A.I.S.I. - 316SS
7 = Monel

GENERAL PURPOSE CODE	"P"	DIMENSIONS		
		BORE	"D"	"Q"
WTS-260A	1/2" NPT	.260"	.500"	.625
WTS-260B	3/4" NPT	.260"	.500"	.750
WTS-260C	1" NPT	.260"	.500"	.875
WTS-385A	1/2" NPT	.385"	.680"	.680
WTS-385B	3/4" NPT	.385"	.766"	.766
WTS-385C	1" NPT	.385"	.766"	.875

CODE	ELEMENT LENGTH "A"	INSERTION "U"		LAG. EXT. "T"
		W/O LAG	WITH LAG	
04	4"	2-1/2"	-	-
06	6"	4-1/2"	2-1/2"	2"
09	9"	7-1/2"	4-1/2"	3"
12	12"	10-1/2"	7-1/2"	3"
15	15"	13-1/2"	10-1/2"	3"
18	18"	16-1/2"	13-1/2"	3"
24	24"	22-1/2"	19-1/2"	3"

Pressure - Temperature Rating (lbs/sq. in)

MATERIAL	TEMPERATURE						
	70	200	400	600	800	1000	1200
Brass	5000	4200	1000	--	--	--	--
Carbon Steel	5200	5000	4800	4600	3500	1500	--
A.I.S.I. - 304	7000	6200	5400	5400	5200	4500	1650
A.I.S.I. - 316	7000	7000	6200	6100	6100	5100	2500
Monel	6500	6000	5400	5200	5200	1500	--

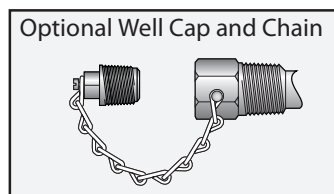

Heavy Duty Thermowells for 1/4" and 3/8" Sensors

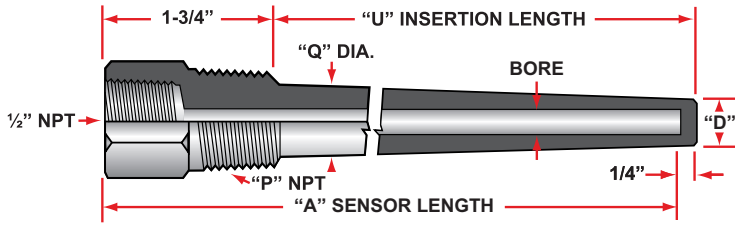

Tapered shank wells provide greater stiffness for the same sensitivity. The higher strength to weight ratio gives these wells higher material frequency than for equivalent length straight shank wells.

For a broader selection of thermowells, including flanged, weld-in, socket-weld, and limited spaced thermowells consult the factory or visit us on the web at www.GICThermodynamics.com

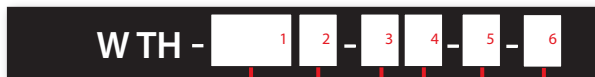
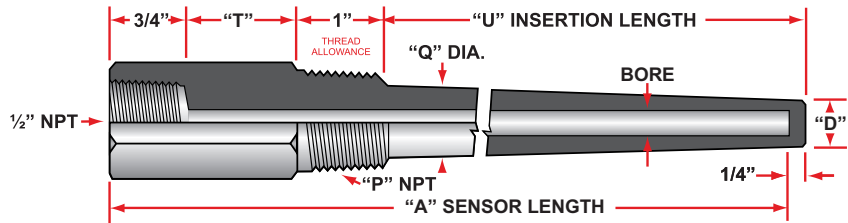

1. Well Bore Dia.

260 = For 1/4" Dia. Sensors
385 = For 3/8" Dia. Sensors

2. Process Connection "P"

A = 1/2" NPT B = 3/4" NPT C = 1" NPT

3. Sensor Length "A" (See Chart)

06 = 6" 12 = 12"
09 = 9" 15 = 15"

4. Lagging

N = Non-Lagging
L = Lagging

5. Special Options

N = None
1 = Brass Well Cap and Chain
4 = 304SS Well Cap and Chain
6 = 316SS Well Cap and Chain
Z = Other (Consult Factory)

6. Well Material

1 = Brass
2 = Carbon Steel
4 = A.I.S.I. - 304SS
6 = A.I.S.I. - 316SS
7 = Monel



CODE	"P"	DIMENSIONS		
		BORE	"D"	"Q"
WTH-260A	1/2" NPT	.260"	.625"	.625
WTH-260B	3/4" NPT	.260"	.625"	.750
WTH-260C	1" NPT	.260"	.625"	.875
WTH-385A	1/2" NPT	.385"	.625"	.680
WTH-385B	3/4" NPT	.385"	.766"	.766
WTH-385C	1" NPT	.385"	.766"	.875

CODE	ELEMENT LENGTH "A"	INSERTION "U"		LAG. EXT. "T"
		W/O LAG	WITH LAG	
04	4"	2-1/2"	-	-
06	6"	4-1/2"	2-1/2"	2"
09	9"	7-1/2"	4-1/2"	3"
12	12"	10-1/2"	7-1/2"	3"
15	15"	13-1/2"	10-1/2"	3"
18	18"	16-1/2"	13-1/2"	3"
24	24"	22-1/2"	19-1/2"	3"

Pressure - Temperature Rating (lbs/sq. in)

MATERIAL	TEMPERATURE						
	70	200	400	600	800	1000	1200
Brass	5000	4200	1000	--	--	--	--
Carbon Steel	5200	5000	4800	4600	3500	1500	--
A.I.S.I. - 304	7000	6200	5400	5400	5200	4500	1650
A.I.S.I. - 316	7000	7000	6200	6100	6100	5100	2500
Monel	6500	6000	5400	5200	5200	1500	--

Metal Protection Tubes

Protection tubes are designed to protect sensors against corrosion, contamination and physical damage. Used in many industrial applications to extending the life of expensive temperature sensor elements. Protection tubes are often a more economical alternative to thermowells.

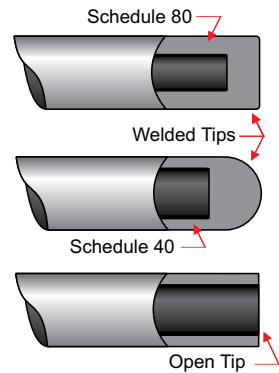
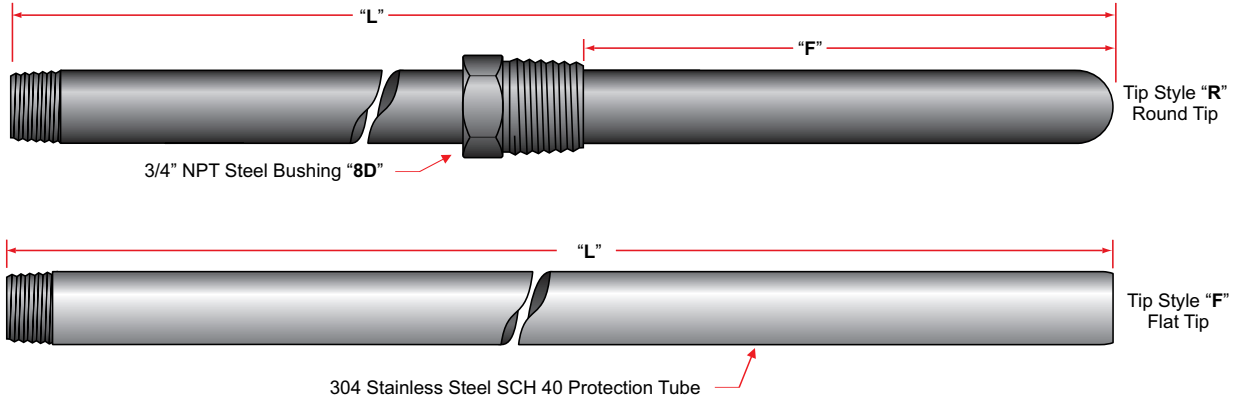

For more information on Ceramic Protection Tubes visit www.GICsensors.com

PT 1 - 2 - 3 - 4 - 5 - 6 - 7

1. Tip Style

Flat Tip F (Std)

Round Tip R

Open Tip O

2. Sheath Diameter

I = 1/4" NPT P = 1/2 NPT

J = 3/4" NPT X = 1" NPT

(Consult Factory for other sizes)

3. Pipe Schedule

4 = Sch 40 (Std) 8 = Sch 80

See pg 51 (Diagram PT-PIPE)

4. Sheath Material

B = Black Steel (Std) 4 = 304SS (1650°F)

6 = 316SS (2150°F) I = INCONEL (2150°F)

M = Monel (2150°F) L = LT-1* (2500°F)

*LT-1 is only available in certain configurations Consult Factory

5. Sheath Length "L" (inches)

6. Fittings (Metric fittings also available)(Consult Factory for other sizes)

N = None (Std) F = Flange (Fixed & Adjustable Flanges are available) Z = Special

NPT Fittings	3/4" NPT	1" NPT	1-1/2" NPT	2" NPT	SPECIAL
Welded Bushing (Stainless)	1D	1B	1C	1D	1Z
Welded Bushing (Steel)	8D	2B	2C	2D	2Z

*Welded bushing must be at least one NPT size greater than sheath .

7. Fitting Location "F" (Inches from tip) N = No Fitting (Std)

Protection Tube Materials

SHEATH MATERIAL	MAXIMUM OPERATING TEMPERATURE	REMARKS
Black Steel	1000°F (540°C)	Satisfactory in all except corrosive atmospheres
304 Stainless Steel	1600°F (870°C)	Resistant to oxidation and corrosion.
316 Stainless Steel	1600°F (870°C)	Better corrosion resistance than 304SS
Inconel 600	2100°F (1150°C)	Excellent strength in high temp applications
Monel	900°F (480°C)	Excellent for sea water, Highly corrosive environments
LT-1 Metal/Ceramic	2500°F (1380°C)	Excellent oxidation resistance to 2200°F Resists wetting from metals, alloys and slags

For more information on protection tube materials and go Engineering Data at www.GICsensors.com

Insulated Thermocouple & Extension Wire

GIC Thermodynamics offers thermocouple and thermocouple extension wire in many different gauge sizes and insulation materials designed to meet varied applications. Stranded or solid conductors in either Standard or Special limits of error accuracies are available. Thermocouple grade wire is recommended when it is being used as the sensor. If the requirement is to extend the signal at lower temperatures, the extension grade is recommended.

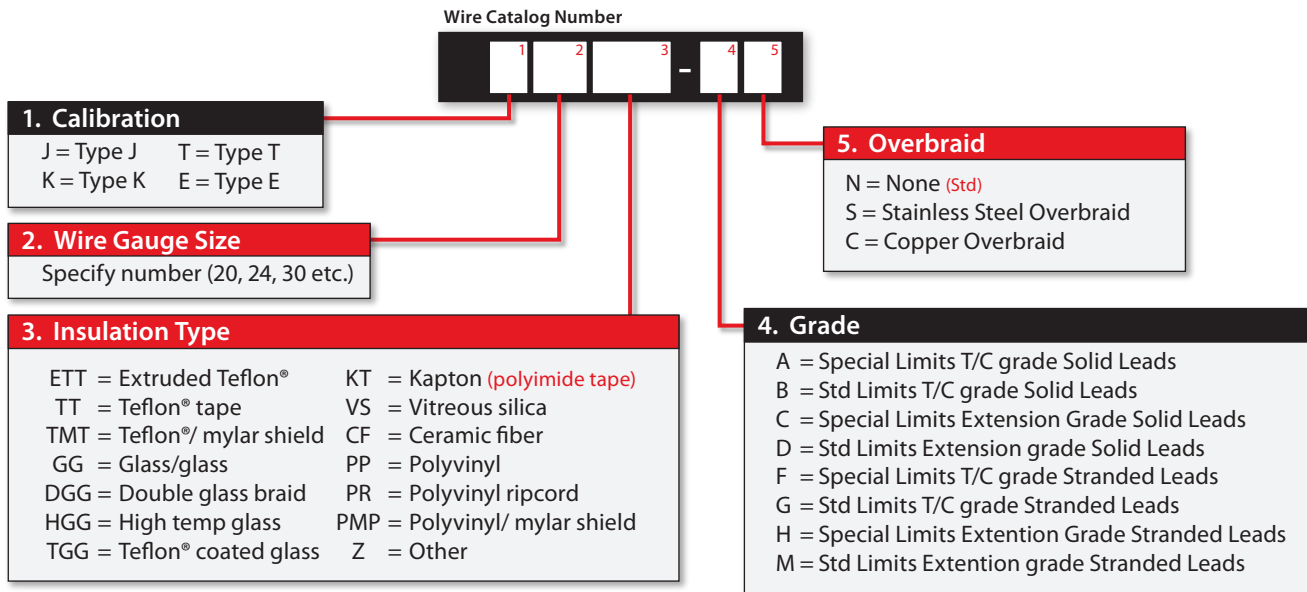

For Multi-Pair Cable go to: GICThermodynamics.com

Insulation Characteristics

TYPE	SINGLE CONDUCTOR		DUPLEX CONDUCTOR		TEMP RATING		PHYSICAL PROPERTIES		
	INSULATION	IMPREGNATION	INSULATION	IMPREGNATION	CONTINUOUS	SINGLE	COLOR CODE	ABRASION RES.	MOISTURE RES.
CF	Ceramic Fiber yarn	-	Ceramic Fiber yarn	-	2200 F	2600 F	no	Good	Fair
VS	Vitreous Silica yarn	-	Vitreous Silica yarn	-	1800 F	2000 F	no	Fair	Fair
HGG	High Temp Glass braid	Impregnated resin	High Temp Glass braid	impregnated resin	1300 F	1600 F	yes	Good	Good
DGG	Double Glass Braid	Silicone Modified Resin	Glass Braid	Silicone Modified Resin	900 F	1000 F	yes	Good	Good
GG	Glass Braid	Silicone Modified Resin	Glass Braid	Silicone Modified Resin	900 F	1000 F	yes	Fair	Good
WGG	Double Glass Wrap	Impregnated Resin	Glass Braid	Silicone Modified Resin	+ 900 F	+ 1000 F		Fair	Good
TGG	TFE coated glass over Teflon® Tape	TFE	Teflon® Coated Fiberglass	TFE	900 F	1000 F	yes	Good	Excellent
KT	double polyimide tape layer	Impregnated	double fused polyimide tape	Impregnated	+ 600 F	+ 800 F	tracers	Excellent	Excellent
TT	TFE Tape	-	Fused TFE Tape	-	500 F	600 F	yes	Good	Excellent
ETT	Teflon® FEP Extr.	-	Teflon® FEP Extr.	-	+ 400 F	500 F		Excellent	Excellent
TMT	FEP aluminized mylar tape	-	FEP	-	400 F	500 F	yes	Excellent	Excellent
PMP	Polyvinyl alum/mylar shield	-	Polyvinyl	-	220 F	220 F	yes	Good	Excellent
PP	Polyvinyl	-	Polyvinyl	-	220 F	220 F		Excellent	Excellent
PR	Polyvinyl	-	-	-	220 F	220 F	yes	Good	Excellent

Most Thermocouples styles can be built with any of these wire choices. If you don't see the wire that you want listed under Lead-wire Options on the assembly page, simply choose Option "Z" for Other, and note the Wire Catalog Number that you prefer.

2-Wire Microprocessor Head Mount Transmitters

Basically, a transmitter is a signal conditioner. It accepts a low level input signal from a sensor, a millivolt signal from a thermocouple or a resistance signal from a RTD (Pt100), and provides an output signal that is directly proportional to the input-signal. Most transmitters provide a current output signal (generally 4-20 mA or 0-20 mA signal) rather than a voltage output.

Conversion to a current signal virtually eliminates any interference from line noise and allows accurate transmission over relatively long distances using ordinary uncompensated copper wire.

2-Wire Transmitters

2-wire transmitters allow the same two wires to carry both the transmitter power and the transmitter signal. The transmitter electronics are designed to use less than 4 mA for internal consumption. As the input signal (from the sensor) changes, the current drawn from the power supply will vary from 4 to 20 mA in direct proportion to the sensor change. This current change is referred to as the "loop current". This 2-wire technique allows

significant savings by reducing the size of the transmitter installation as well as a reduction of installation time and materials required while still providing accurate signal transmission.

Ideally, the 2-Wire Transmitter should be placed in the sensor connection head to provide the best signal. A wide range of 2-Wire head-mount transmitters (in both isolated and non-isolated versions) to fit almost any standard connection head is offered. When a 2-Wire Head-Mount Transmitter cannot be used (because of extreme temperature or vibration), a complete line of 2-Wire Rail Mount Transmitters are available.

GIC offers a transmitter or every application and accuracy. For a larger selection of the latest transmitters and options plus in-depth specifications see our website at www.GICthermodynamics.com

Universal Transmitter (Option D)

The MP82700 is one of the smallest and most advanced 2-wire head mounting microprocessor transmitters in the industry. With its small size, it is able to fit in standard connection heads yet still provide the most advanced microprocessor technology available. Easily programmed in less than one minute, the Mp82700 can be used for all your different sensor and range requirements.

Standard Features:

- Universal Input -
12 T/C's : J, K, E, T, R, S, B, C, D, N, L, U
8 RTD's : PT100, PT500, PT1000, NI100,
NI500, NI1000, CU10, CU100
- Millivolt (V),
Resistance (Ohms)
- Fully Isolated
- ATEX Approval
- Fully Linearized
- High Accuracy (0.1%)
- Small Size
- 5-year warranty
- RFI/EMI Immunity (DC to 1GHz)

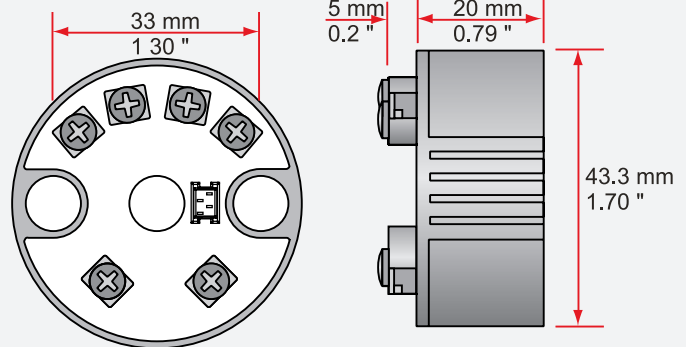

MP82700 -

1 Options:

- D = Plug-in Loop Powered Readout
- IF = Interface and Software
- CW = Connection Head with Window
- EX = Intrinsically Safe Approval
- FM = Intrinsically Safe Approval
- H = Hart Protocol

*Note: If you require a Rail-mount Version of this assembly, order as part number MP88700

If you do not require all the features of the MP82700 there are other models to consider:

Multi-Input Transmitter (Option E)

T/C (J,K,E,T,N) RTD (PT100 RTD)

- Fully Linearized
- High Accuracy
- RFI Protected
- Small Size
- ATEX Approval
- 5-Year Warranty

MP82800 - []

1 Options:

D = Plug-in Loop Powered Readout
 IF = Interface and Software
 CW = Connection Head with Window
 EX = Intrinsically Safe Approval
 FM = Intrinsically Safe Approval

RTD Transmitter (Option B)

PT100 RTD (only)

- Fully Linearized
- High Accuracy
- RFI Protected
- Small Size
- ATEX Approval
- 5-Year Warranty

MP82800-R - []

1. Options:

D = Plug-in Loop Powered Readout
 IF = Interface and Software
 CW = Connection Head with Window
 EX = Intrinsically Safe Approval

Field Programable RTD Transmitter (Option C)

PT100 RTD (only)

- Fully Linearized
- High Accuracy
- **Push Button Programable**
- 5-Year Warranty

MP82850-R - []

1 Options:

D = Plug-in Loop Powered Readout
 CW = Connection Head with Window

TRANSMITTER OPTIONS

Plug-in Loop Powered Readout (D)
 The “display” is a loop powered plug-in LCD Readout for local display of the measured temperature. Easy to connect on top of the transmitter with the interface connector.

Connection Head with Window (CW)
 This specially designed DAN connection head is suitable for microprocessor head mount transmitters with display (D). The display will be attached by a connection cable with plugs - the same method as the Interface (IF) connection.

Interface and Software (IF)
 The interface and “Point ‘n Click” software program is suitable for all micro-processor based transmitters (Mp series). Using your PC and the “point ‘n click” software, transmitters are easily programmed in less than one minute.

Intrinsically Safe Approval (EX)

Intrinsically Safe Approval (FM)

Specifications

Input RTD	Pt100, Pt500, Pt1000 Ni100, Ni500, Ni1000 Cu10, Cu100
Input T/C	K, J, L, T, U, E, R, S, B, C, D, N
Input V	
Input Ohm	
Minimum Span	See Table below
Output	4..20 mA or 20..4 mA
Linearization	On / Off
Supply *	10..40 VDC, Polarity Protected
Supply Effect	0.001%/V
Max. Ripple	10 V PP, Min Vbat=10 Vdc
Zero Drift	±0.01%/°C or ±0.02 °C/°C
Span Drift	±0.005%/°C or ±0.01 °C/°C
Long Term Drift	±0.05%/Year
Cold Junction Drift	±0.01 °C/°C
Excitation Current, RTD	0.1 mA
Sensor Lead Resistance, RTD	500 Ohm max.
Sensor Lead Resistance Effect	0.001 °C/Ohm
Sensor Lead Resistance, T/C	10,000 Ohm max.
Open Circuit Detection	Upscale / Downscale
Load Capacity	Vbat-10V / 20 mA
Response Time	≤ 3 sec.
Startup Time	20 sec.
Warm-up Time	5 min.
Isolation	500 VCD
Ambient Operating Temp.	-40...+85°C
Storage Temperature	-40...+100°C
Ingress Protection	IP30
Housing Material	Zinc Alloy (ZAMAK 5) epoxy coated
Housing Dimension	43mm Dia. x 27mm H.

GIC offers a large variety of transmitters for every need. For the latest transmitter options and in-depth specifications see our website at

www.GICThermodynamics.com

Installation and Maintenance Suggestions

THERMOCOUPLE INSTALLATION

1. Seat the thermocouple firmly into the area to be measured far enough to minimize errors. Select proper location and depth to avoid "stagnant areas" to get the best representative temperature
2. For maximum life and reliable readings use the largest diameter probe possible. And caution should be taken to insure that T/C's are not too close to a heating element or in a direct flame.
3. When measuring high temperatures install assemblies vertically to avoid tube sagging. With head assemblies take caution to keep excessive heat from the terminal block.
4. Use only compensating extension wire of the calibration designated on the Instrument being used.
5. Observe color coding (negative lead is always red) and make certain polarity is correct.
6. Avoid stray signal pick up. Install unit at least one foot from AC power lines. Use ungrounded sensors where high electrical noise is possible.
7. Do not run thermocouple wires in same conduit with electrical wires.
8. All wire hook ups must be good firm mechanical connections. Clean the wire ends to brightness.
9. Keep splices to a minimum (have none at all if possible). Silver solder all splices.
10. All connectors should be compensated including ring or spade lugs and terminal strips.
11. For maximum life use the largest diameter probe possible.
12. In high vibration environments use stranded leadwire.

RTD INSTALLATION

1. Connect the RTD leads to the instrument per instructions noted by the instrument manufacturer.
2. All wire hook ups must be good firm mechanical connections.
3. Insert the probe into the area to be measured far enough to minimize conduction errors.
4. Do not exceed the temperature range of the RTD element.
5. Do not bend probe unless it has been designated as field bendable.

THERMOCOUPLE MAINTENANCE

1. Thermocouples will deteriorate due to contamination from their environments. Regular periodic checks should be made of the thermocouples to determine their life cycle and replacement requirements.
2. Check or calibrate a thermocouple in its installed position and location if possible.
3. For reliable readings, thermocouples removed for tests or inspections should be returned to the same location and immersion depth.
4. Once a thermocouple has been used at one immersion depth it should not be used at any other depth.
5. Do not use a thermocouple to measure a low temperature once it has been used at a very high temperature.
6. Do not use a thermocouple with deteriorated protection tubes.
7. A deteriorated thermocouple will cause a low reading. Always replace a deteriorated thermocouple.
8. Tolerances of thermocouple change over time and usage so they have a finite useful life. Do not recalibrate thermocouples once they are out of tolerance.
8. Do not run two instruments in parallel from a single thermocouple. This will result in instrument imbalance. Use a dual element thermocouple.

RTD MAINTENANCE

1. Check RTD's on a regular basis to determine replacement requirements.
2. Test probes periodically for ungrounded condition. Unit should read 100 meg ohms minimum at room temperature.
3. When a replacement probe is needed the new element must meet all the following specifications:

Element material	Temp. coefficient
Element accuracy	Maximum Temp.
4. The measuring current to the element should be kept to a minimum to keep self-heating at a negligible level. (3 MA or less)